



Low Volume Rotating Vane Flowmeter for liquids



measuring
•
monitoring
•
analysing

DPL



Model: DPL

- Measuring ranges:
0.025-0.5...1-25 L/min water
- Linearity: $\pm 1\%$
- p_{\max} : 10 bar; t_{\max} : 70 °C
- Viscosity range: low viscosity
- Connection: G 1/2 male,
hose connector
- Material of case: PP
- Output: pulse
- Without magnets or metal parts
- Medium: infrared light transmissive



Model: DPL
with pointer
indication



Model: DPL with
compact electronics



KOBOLD companies worldwide:

ALGERIA, ARGENTINA, AUSTRALIA, AUSTRIA, BELGIUM, BULGARIA, CANADA, CHILE, CHINA, COLUMBIA, CZECHIA, DOMINICAN REPUBLIC, EGYPT, FRANCE, GERMANY, GREAT BRITAIN, HUNGARY, INDIA, INDONESIA, ITALY, MALAYSIA, MEXICO, MOROCCO, NETHERLANDS, PERU, PHILIPPINES, POLAND, ROMANIA, SINGAPORE, SLOVAKIA, SOUTH KOREA, SPAIN, SWITZERLAND, TAIWAN, THAILAND, TUNISIA, USA, VENEZUELA, VIETNAM

KOBOLD Messring GmbH
Nordring 22-24
D-65719 Hofheim/Ts.
☎ Head Office:
+49(0)6192 299-0
☎ Sales DE:
+49(0)6192 299-500
☎ +49(0)6192 299-23398
info.de@kobold.com
www.kobold.com



Application

The KOBOLD flowmeters model DPL are used to measure and monitor liquids. Its compact design allows it to be used in equipment where space is at a premium. The large number of pulse evaluation options offered means that the system is suited for a wide range of applications.



Areas of Application

- Low viscosity and transparent liquids
- Non-conductive liquids
- Volume dosing with external electronics
- Filter aid
- Beverage industry

Technical Details

Accuracy:	±2.5% f. s. ±5% f. s. (OEM version)
Linearity:	1% f. s.
Medium temperature:	-40...+70 °C
Ambient temperature:	-30...+60 °C
Max. operating pressure:	10 bar
Protection:	IP 65

Materials

Housing:	polypropylene
Rotating vane:	polypropylene
Axle/bearing:	sapphire
Vane mount:	polysulfone
Gasket:	NBR, FPM or EPDM

Operating Principles

The medium flows through a specially shaped flow housing and causes a vane to rotate. This rotary motion is sensed by optoelectronics in a non-contacting manner, and converted to an asymmetric frequency signal or an analogue signal. A frequency divider with symmetrical output is available as an option. The frequency is proportional to the flow velocity.

The vane is sapphire-supported: this ensures a high degree of linearity and long service life.

Electronics

● Frequency Output (OEM without CE-Sign)

Power supply:	4.5-12 V _{DC}
Supply current:	typically 7 mA
Signal amplitude high:	approx. power supply
Signal amplitude low:	≤ 0.2 V
Transmitter cut-off voltage:	3 V max.
Transmitter supply current:	15 mA-25 mA
Output loss:	max. 2.5 mWatt
Electrical connection:	solder pins
Pulse output:	NPN, open collect., max. 10 mA

● Frequency Output (option frequency divider)

Power supply:	24 V _{DC} ±20%
Supply current:	40-50 mA
Signal amplitude high:	approx. power supply
Signal amplitude low:	≤ 0.2 V
Transmitter cut-off voltage:	max. 2.5 mWatt
Output loss:	plug connector M12x1 (option: 2 m PVC cable)
Division ratio (option):	1 ... 1/128 factory set
Pulse output:	PNP, open collector, max. 20 mA

● Analogue Output (option plug-on display)

Power supply:	24 V _{DC} ±20%
Output:	0-20 mA or 4-20 mA, 3-wire technology
Max. load:	500 Ω
Electrical connection:	plug connector M12x1 or DIN 43 650
Option:	plug-on display (with plug connector DIN 43 650 only)

● Compact Electronics

Display:	3-position LED
Analogue output:	(0)4...20 mA adjustable max. 500 Ω
Switching outputs:	1 (2) semiconductor PNP or NPN, set at the factory
Contact operation:	programmable N/C / N/O contact
Setting:	via 2 buttons
Power supply:	24 V _{DC} ±20%, approx. 100 mA, 3-wire technology
Electrical connection:	plug connector M12x1

● Pointer Indication with Analogue Output

Housing:	aluminium (PA6 GF30)
Display:	moving coil instrument, 240° display
Power supply:	24 V _{DC} ±20%
Output:	(0)4...20 mA, set at the factory, 3-wire technology
Max. load:	250 Ω
Electrical connection:	plug connector M12x1

Order Details (Example: **DPL-1P05 G4 0000**)

Meas. range [L/min] water	Approx. frequency [Hz] at max. value	Approx. pressure loss [bar] at max. value	Gasket model			Connection	Electronic analyser
			NBR	FPM	EPDM		
0.025 - 0.5	272	0.77	DPL-1P05	DPL-1V05	DPL-1E05	G4..= G ½ male S4..= hose connector (for inner diameter of hose 12 mm + 14 mm)	Frequency output ..0000 = frequency output, NPN, without cable (OEM), no CE ..F300 = frequency output, plug connector M12x1, PNP ..F320 = frequency divider 1:2, plug connector M12x1, PNP ..F340 = frequency divider 1:4, plug connector M12x1, PNP ..F390 = frequency divider 1...1/128, plug connector M12x1, PNP ..F500 = frequency output, PNP, 2 m PVC cable ..F520 = frequency divider 1:2, 2 m PVC cable, PNP ..F540 = frequency divider 1:4, 2 m PVC cable, PNP ..F590 = frequency divider 1...1/128, 2 m PVC cable, PNP Analogue output ..L303 = 0-20 mA output, M12x1 plug connector ..L343 = 4-20 mA output, M12x1 plug connector ..L403 = 0-20 mA output, plug connector DIN 43 650 ..L443 = 4-20 mA output, plug connector DIN 43 650 Compact electronics* C3R = LED display, 2x open collector, PNP, plug connector M12x1 C30M = LED display, 2x open collector, NPN, plug connector M12x1 C34P = LED display, 4-20 mA, 1x open coll., PNP, plug con. M12x1 C34N = LED display, 4-20 mA, 1x open coll., NPN, plug con. M12x1 Pointer indication* Z300 = 240° pointer indication, 0-20 mA, plug connector M12x1 Z340 = 240° pointer indication, 4-20 mA, plug connector M12x1
0.05 - 1.8	471	0.77	DPL-1P10	DPL-1V10	DPL-1E10		
0.2 - 6	505	0.70	DPL-1P15	DPL-1V15	DPL-1E15		
0.4 - 12	265	1.0	DPL-1P20	DPL-1V20	DPL-1E20		
1 - 25	399	1.3	DPL-1P25	DPL-1V25	DPL-1E25		

*Please specify flow direction in writing

Plug-on Display

for model DPL...L443 (with 4-20 mA output and DIN plug connector)

Description	Order number
3-position LED, plug connector DIN 43 650, 3-wire, power supply through analogue output	AUF-3000

Electrical Connection

DPL..0000

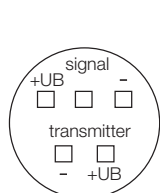

DPL..L3 / DPL..Z / DPL..F3

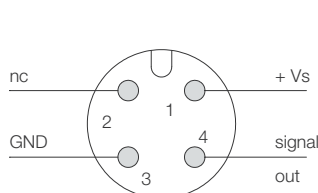

DPL..C

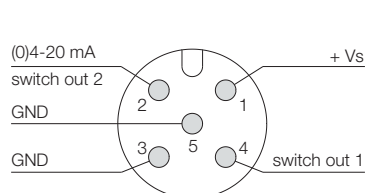

DPL..L4

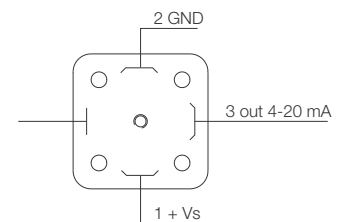

DPL...F5...

- brown: +Vs
- blue: GND
- black: signal



Low Volume Rotating Vane Flowmeter Model DPL

Dimensions

DPL-...0000

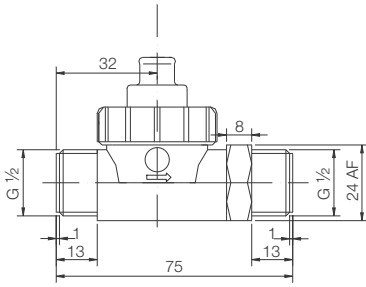

DPL-...F3.; DPL-...L3...

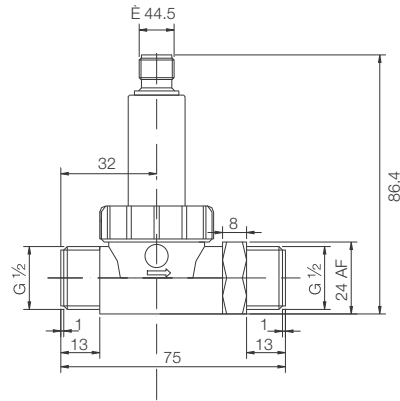

DPL-...C with compact electronics

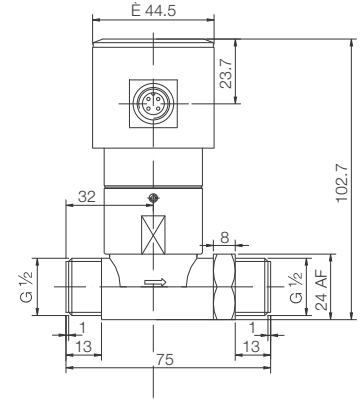

DPL-...L4... with analogue output and plug-on display

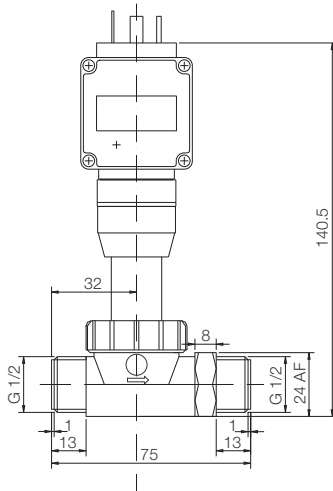

DPL-...Z with analogue output and pointer indication

