



Conductive Level Limit Switches for Conductive Liquids



measuring
•
monitoring
•
analysing



- Pressure: max. 30 bar
- Temperature: max. 150°C
- Connection: G 1/2, G 1 1/2
- Electrode material: stainless steel, Hastelloy, Titanium Polyolefine or PTFE coated



KOBOLD companies worldwide:

ARGENTINA, AUSTRIA, BELGIUM, CANADA, CHILE, CHINA, COLOMBIA, CZECHIA, FRANCE, GERMANY, GREAT BRITAIN, INDIA, IRAN, INDONESIA, ITALY, MALAYSIA, MEXICO, NETHERLANDS, PERU, POLAND, SINGAPORE, SLOVAKIA, SPAIN, SWITZERLAND, THAILAND, USA, VENEZUELA, VIETNAM

KOBOLD Messring GmbH
Nordring 22-24
D-65719 Hofheim/Ts.
☎ +49(0)6192 299-0
Fax +49(0)6192 23398
E-Mail: info.de@kobold.com
Internet: www.kobold.com

Model:
NES



Description

KOBOLD limit switches of model NES are used for level monitoring and pump control of conductive liquids. The design without any moving parts allows service with critical media with, for example, solid content, negligible density or high viscosity. The instruments operate on the conductive principle. A low a.c. voltage is applied between the conductive wall of the tank or the earth electrode (longest electrode) and a switching point electrode. If the conductive medium touches the electrodes, a negligible alternating current flows across the electrodes and the conductive medium to the electrode relay. The relay amplifies the alternating current and operates an relay or a pump controller. An electrode relay of type NE-104 is required per switch point for signalling. For min./max. control two switching point electrodes must be connected to the relay. Relay NE-304 operates as two single relays (NE-104).

Dimensions

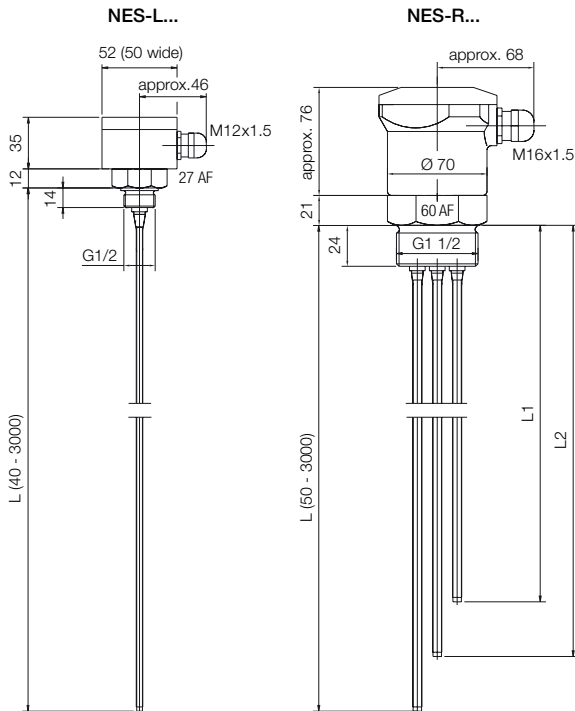

Technical Details

- Housing: Polyamide or Aluminium
- Connections: Polypropylene, PTFE or stainless steel 1.4571
G 1/2 (single electrode)
G 1 1/2 (2-6-fold electrode)
- Electrodes: stainless steel 1.4571, Hastelloy or Titanium
- Max. length of electrodes: 3000 mm
- Electrode coating: Polyolefine, complete coating
PTFE complete or partial coating
- No. of electrodes: 1 - 6
- Max. temperature: 90°C (Polyolefine coating)
150°C (PTFE coating)
- Max. pressure: 6 bar (PTFE connection)
15 bar (Polypropylene connection)
30 bar (stainless steel connection)
- Min. conductivity: approximately 20 µS/cm
- Protection: IP 65

Electrode relay

For technical details please refer to pp. 41-44 (Electrode relay model NE).

Order Details for electrode relay

Description of electrode relay	Supply		
	Order no. 24 V _{AC}	Order no. 230 V _{AC}	Order no. 110 V _{AC}
1 limit signal or 1 min./max. control	NE-1042	NE-1040	NE-1041
2 limit signals or 2 min./max. controllers	NE-3042	NE-3040	NE-3041



Order Details (Example: NES-REAP1)

Model	Description	Housing	Electrode material	Electrode coating	Screwed fitting	Number of electrodes*
NES-	Conductive Level Limit Switches	R = Polyamide L = Aluminium	E = Stainless steel	A = Polyolefine complete coating	E = Stainless steel P = Polypropylene	1 = 1 electrode 2 = 2 electrodes 3 = 3 electrodes 4 = 4 electrodes 5 = 5 electrodes 6 = 6 electrodes
			H = Hastelloy C T = Titanium E = Stainless steel	T = PTFE partial coating V = PTFE-complete coating	E = Stainless steel F = PTFE	

*Please show the length of electrodes in the clear text