



Rotating Vane Flow Meter, Counter, Doser for liquids



measuring
•
monitoring
•
analysing



- Measuring range: 0.1 - 0.5 to 3 - 60 L/min
- Measuring accuracy: 2.5 % f. s.
- p_{max} : 16 bar
- t_{max} : 80 °C
- Process connection:
G 1/4; G 1/2; G 3/4 female
1/4 NPT; 1/2 NPT; 3/4 NPT
- Materials:
PTFE housing or brass housing

KOBOLD companies worldwide
ALGERIA, ARGENTINA, AUSTRALIA, AUSTRIA, BELGIUM, BULGARIA, CANADA, CHILE, CHINA,
COLUMBIA, CZECHIA, DOMINICAN REPUBLIC, DUBAI, EGYPT, FRANCE, GERMANY, GREAT
BRITAIN, HUNGARY, INDIA, INDONESIA, ITALY, MALAYSIA, MEXICO, MOROCCO, NETHERLANDS,
PERU, PHILIPPINES, POLAND, ROMANIA, SINGAPORE, SLOVAKIA, SOUTH KOREA, SPAIN,
SWITZERLAND, TAIWAN, THAILAND, TUNISIA, UKRAINE, USA, VENEZUELA, VIETNAM

KOBOLD Messring GmbH
Nordring 22-24
D-65719 Hofheim/Ts.
☎ +49(0)6192 299-0
Fax +49(0)6192 23398
E-Mail: info.de@kobold.com
Internet: www.kobold.com

Model:
DFT



Brass Housing



PTFE Housing



Working Method

The established vane technology has proven itself a million times worldwide for measuring and monitoring the flow of different media through piping. KOBOLD flow meters/monitors work with this proven principle and offer many benefits.

The heart of the new KOBOLD vane is an embedded ring magnet; it is hermetically sealed from the flow medium. It transfers, in a non-contacting manner, the rotary motion of the vane to a Hall sensor attached to the case (in order to save space). This converts the rotary motion to a frequency signal that is proportional to the flow rate. The downstream KOBOLD evaluating electronics can output this signal to a display, convert it to (0(4) - 20 mA, 0 - 10 V) analogue signal, or count it. It may also be used to switch up to two limit contacts. The ready and control states of the limit value relay are indicated by LEDs.

The modular design of KOBOLD flow monitors and measuring instruments is a system that can be universally applied; it is reasonably priced; and requires minimum space when in service. Very precise measurement results can be achieved, under tough operating conditions along with the KOBOLD electronics. The system is assembled with the electronics and delivered ready for service. The electronics are adjusted and tuned for use with the sensor. When retrofitted for other measuring ranges, the system may be readjusted with a similar device at any time.

Fields of Application

The KOBOLD meters/monitors are suitable for the following applications:

- cooling water monitoring
- general mechanical engineering
- waste water treatment
- all heavy goods industry
- chemical industry

Technical Details

Sensor

Measuring accuracy:	2.5 % f. s. 5 % f. s. (DFT-...0000)
Medium temperature:	-20 to +80°C
Ambient temperature:	-20 to +80°C
Max. operating pressure:	5 bar (PTFE housing) 16 bar (brass housing)
Max. pressure loss:	see table
Protection:	IP 65

Materials:

Housing/cover:	PTFE or brass
Vane:	PTFE
Axle:	Ceramics Al ₂ O ₃ or sapphire
Bearing:	PTFE
Gasket:	NBR (DFT-11..; DFT-16..) FEP-O-Seal with silicone (DFT-13..; DFT-18..)
Front- and back panel:	Aluminium, black anodized (DFT-13..; DFT-18.. only; not media-contacting)
Screwing:	stainless steel

Electronics

● Frequency output (OEM)

Power supply:	5 - 24 V _{DC}
Power input:	approx. 5 mA
Signal amplitude high:	approx. power supply
Signal amplitude low:	≤0.2 V
Output loss:	max. 2.5 mW
Electrical connection:	connector DIN 43 650
Pulse output:	NPN, open collector, max. 15 mA

● Frequency output (option frequency divider)

Power supply:	24 V _{DC} ±20%
Power input:	40-50 mA
Signal amplitude high:	approx. power supply
Signal amplitude low:	≤0.2 V
Output loss:	max. 2.5 mW
Electrical connection:	connector DIN 43 650
Division factor (option):	0.25...2 factory set
Pulse output:	PNP, open collector, max. 20 mA

● Analogue output (L electronics)

Power supply:	24 V _{DC} ±20%
Output:	0 - 20 mA or 4 - 20 mA, 3-wire or 2-wire (2-wire 4 - 20 mA only)
Max. load:	500 Ω
Electrical connection:	connector DIN 43 650



Technical Details

● Analogue output (MA electronics)

Power supply: 24 V_{DC} +15% / -10%
 24/115/230 V_{AC} ± 20%

Power input: 3.5 W max.

Output: 0(4) - 20 mA or 0-10 V
 (floating, 24 V_{DC} non-isolated)

Max. load: 500 Ω

Electrical connection: 1.5 m cable connection or connector

● Switching output (WM electronics)

Power supply: 24 V_{DC} +15% / -10%
 24/115/230 V_{AC} ± 20%

Power input: 3.5 W max.

Output: changeover contact,
 max. 250 V/5 A

Contact resistance: < 100 mΩ

Electrical connection: 1.5 m cable connection or connector

● K electronics with digital display, min/max. contact, analogue output

Power supply: 24 V_{DC} +15% / -10%

Power input: 5 W max.

Analogue output: 0(4) - 20 mA or 0-10 V

Max. load: 500 Ω

Switching output: min.- and max.- changeover contact, max. 24 V/2A

Hysteresis: 2.5% of measured value

Electrical connection: 1.5 m cable connection

Electronics

● DFT-...Exxx (Counter electronics)

Display: LCD module, 2 x 8-digit, illuminated, total, part and flow quantity; units of measurement selectable

Quantity meter: 8-digit

Analogue output: 0(4)...20 mA selectable
 Load: 0...500 Ω or 0-10 V_{DC}
 Load: > 100 kΩ

Relay outputs: 2 relays, max. 250 V / 5 A / 1000 VA

Control elements: 4 keys

Functions: reset, MIN/MAX-memory, flow monitor, part and total quantity monitoring, language

Power supply: 24 V_{DC} ±20 %, 3-line

Power input: approx. 100 mA

Electr. connection: 10-pin cable connection or 2 x plug M12 (5-/8-pin)

● DFT-...Gxxx (Dosage electronics)

Display: LCD module, 2 x 8-digit, illuminated, total, part and flow quantity; units of measurement selectable

Quantity meter: 8-digit

Dosage meter: 5-digit

Analogue output: 0(4)...20 mA selectable
 Load: 0...500 Ω or 0-10 V_{DC}
 Load: > 100 kΩ

Relay outputs: 2 relays, max. 250 V / 5 A / 1000 VA

Control elements: 4 keys

Functions: dosage (relay S2), start, stop, reset, fine dosage, correction quantity, flow monitor, total quantity monitoring, language

Power supply: 24 V_{DC} ±20 %, 3-line

Power input: approx. 100 mA

Electr. connection: 10-pole cable connection or 2 x plug M12 (5-/8-pin)

Frequency/pressure-loss Table

Measuring range [L/min]	Brass housing			PTFE housing		
	Oriface [mm]	Frequency at max. value	Pressure loss at max. value	Oriface [mm]	Frequency at max. value	Pressure loss at max. value
0,2-2,0	2.0	app. 70 Hz	0.8 bar	2.0	app. 80 Hz	0.7 bar
0,5-7	4.3	app. 85 Hz	0.8 bar	4.3	app. 95 Hz	0.5 bar
1-16	5.9	app. 130 Hz	0.8 bar	5.9	app. 140 Hz	0.7 bar
2-36	9.0	app. 130 Hz	0.8 bar	9.0	app. 120 Hz	0.9 bar
3-60	13.5	app. 85 Hz	0.8 bar	13.5	app. 80 Hz	0.9 bar



Order Details (Example: DFT-1101 G2 F400)

Measuring range [L/min]	Model				Connection female thread
	Brass housing ceramic axle	PTFE housing ceramic axle	Brass housing sapphire axle	PTFE housing sapphire axle	
0.1-0.5 0.2-2.0 0.5-7 1-16	DFT-1103.. DFT-1107.. DFT-1116..	DFT-1303.. DFT-1307.. DFT-1316..	DFT-1603.. DFT-1607.. DFT-1616..	DFT-1803.. DFT-1807.. DFT-1816..	..G2.. = G 1/4 ..G4.. = G 1/2 ..N2.. = 1/4 NPT ..N4.. = 1/2 NPT
2-36	DFT-1136..	DFT-1336..	DFT-1636..	DFT-1836..	..G4.. = G 1/2 ..G5.. = G 3/4 ..N4.. = 1/2 NPT ..N5.. = 3/4 NPT
3-60	DFT-1160..	DFT-1360..	DFT-1660..	DFT-1860..	..G5.. = G 3/4 ..N5.. = 3/4 NPT

Evaluating electronics		
<p>OEM frequency output (OEM) ...0000 = NPN, connector DIN 43 650</p> <p>Frequency output ...F400 = PNP, connector DIN 43 650 ...F490 = PNP, connector DIN 43 650, frequency divider 0.25...2</p> <p>Analogue output ...L403 = connector DIN 43 650, 0-20 mA, 3-wire ...L443 = connector DIN 43 650, 4-20 mA, 3-wire ...L442 = connector DIN 43 650, 4-20 mA, 2-wire</p>		
MA electronics with analogue output		
Electronic type	Auxiliary power	Analogue output
..MK.. = 1.5 m cable connection ..MS.. = connector ..MG.. = connector and mating connector	..0.. = 230 V _{AC} ..1.. = 110 V _{AC} ..2.. = 24 V _{AC} ..3.. = 24 V _{DC}	..0 = 0-20 mA ..4 = 4-20 mA ..1 = 0-10 V
WM electronics with 1 contact		
Electronic type	Auxiliary power	Analogue output
..WK.. = 1.5 m cable connection ..WS.. = connector ..WG.. = connector and mating connector	..0.. = 230 V _{AC} ..1.. = 110 V _{AC} ..2.. = 24 V _{AC} ..3.. = 24 V _{DC}	..X = without analogue output
K electronics (display, MIN/MAX-contact, analogue output)		
Electronic type	Auxiliary power	Analogue output
..KK.. = 1.5 m cable connection	..3.. = 24 V _{DC}	..0 = 0-20 mA ..4 = 4-20 mA ..1 = 0-10 V
Counter electronics / dosage electronics		
Electronic type	Electrical connection/ Power supply	Analogue output
E = counter electronics (2 x changer) G = dosage electronics (2 x changer)	3 = plug 2 x M12 / 24 V _{DC} 1 = 1.5 m cable / 24 V _{DC} 9 = x m cable / 24 V _{DC}	4R = 0(4)-20 mA 1R = 0-10 V

Dimensions Brass Housing

DFT...0000

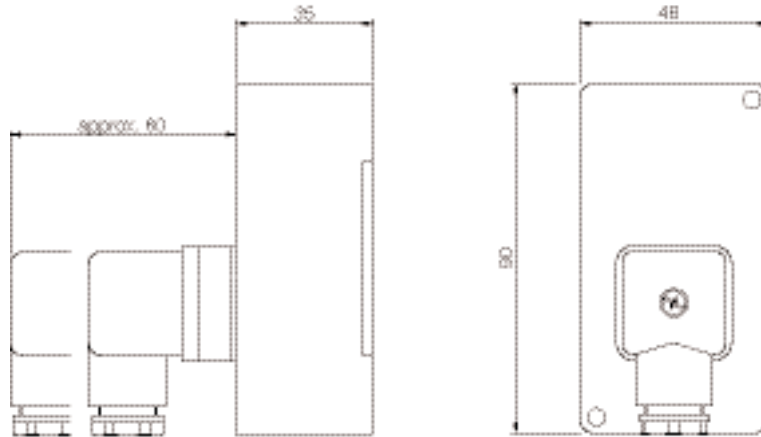

DFT...F4... / DFT...L4...

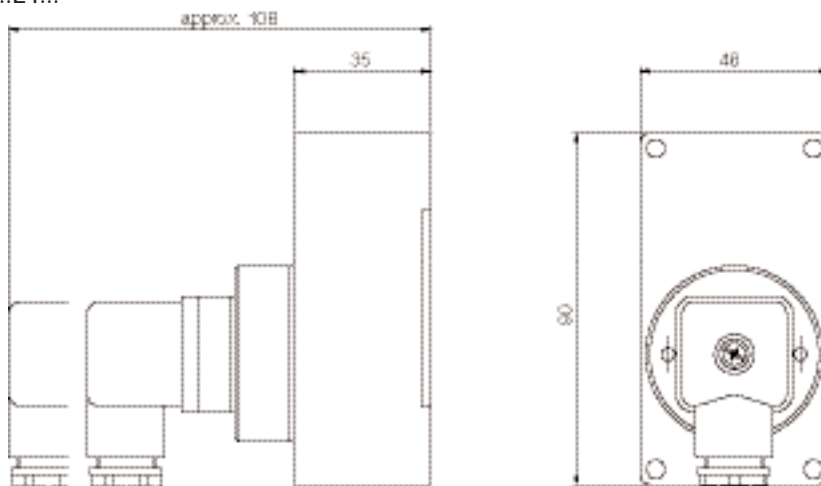

DFT with MA-/WM-/K-/E-/G-electronics

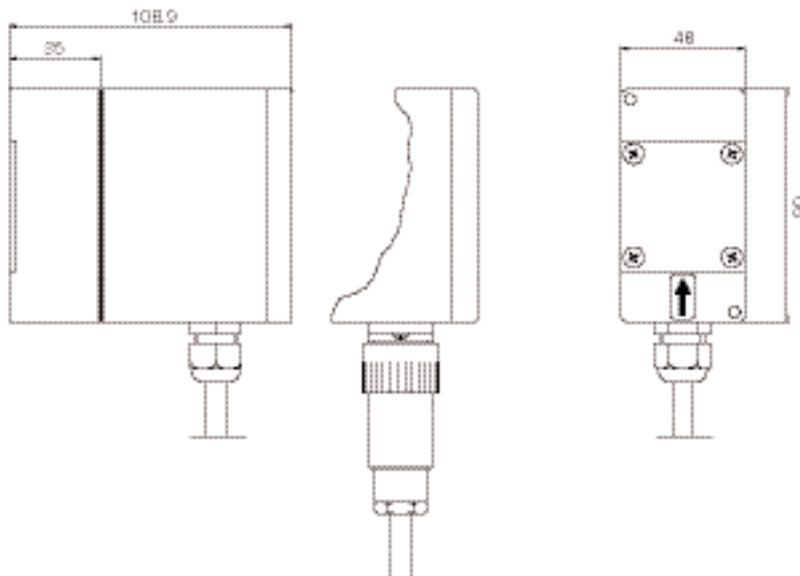

Dimensions Teflon Housing

DFT-...0000

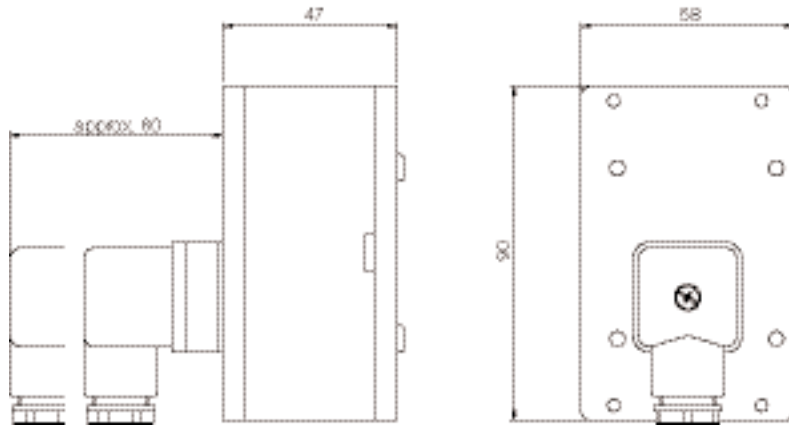

DFT-...F4... / DFT-...L4...

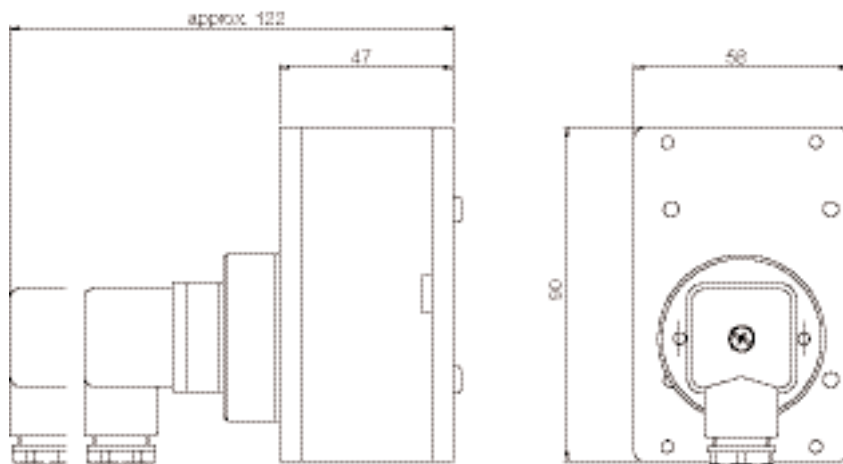

DFT with MA-/WM-/K-/E-/G-electronics

