

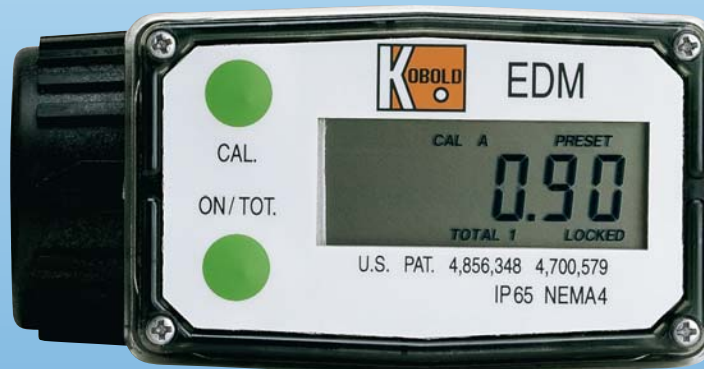

Electronic Turbine Wheel Flow Meter and Counter for Liquids



measuring
•
monitoring
•
analysing



Model: EDM-4

- Measuring ranges:
4 - 40 to 80 - 800 L/min water
- Measuring accuracy: $\pm 1.5\%$ f. s.
- p_{max} : 100 bar; t_{max} : 60°C
- Viscosity range: 1 - 200 mm²/s
- Connection: R_c 1/2" to R_c 1"
- Material: Nylon, Aluminium, St. St.
- Durable lithium battery
(4000 operating hours)
- Automatic switching on and off
- Field calibration possible



KOBOLD companies worldwide:

ARGENTINA, AUSTRIA, BELGIUM, CANADA, CHILE, CHINA, CZECHIA,
FRANCE, GERMANY, GREAT BRITAIN, INDIA, INDONESIA, ITALY,
MALAYSIA, MEXICO, NETHERLANDS, POLAND, SINGAPORE, SLOVAKIA,
SPAIN, SWITZERLAND, THAILAND, USA, VENEZUELA, VIETNAM

KOBOLD Messring GmbH
Nordring 22-24
D-65719 Hofheim/Ts.
☎ +49 (0) 61 92 299-0
Fax +49 (0) 61 92 233 98
E-Mail: info.de@kobold.com
Internet: www.kobold.com

Model:
EDM...



Description

The EDM is very versatile and can be used in many applications. Its built-in, replaceable batteries render it independent of external power supplies. The EDM can be adjusted for use with liquids other than water, because it can be calibrated in situ.

Installation Examples

- Additives, Fuels, Petrol
- Pharmaceuticals (good rinsing)
- Perfume
- Water and demin. water
- Non aggressive chemicals
- Food industry

Function

A turbine wheel rotates inside the device at a speed that is proportional to the flow rate of the liquid to be measured. Ferrite inserts embedded in the rotor blades generate impulses that are inductively sensed and electronically converted and displayed.

Calibration

The built-in microprocessor allows a variety of calibrations. These are required for lightly viscous liquids, for greater measuring accuracy and measurements using units other than liters (eg gallons).

Installation

The EDM can be installed in any position. It is designed for one direction of flow, which is marked by an arrow on the housing and which must be observed. To obtain the best accuracies, the EDM should be calibrated in the installation position with the liquid to be measured; it should be inspected at regular time intervals.

Electronic Features

- Automatic switching on when there is flow or manual display by pressing the "Display" knob
- Automatic switching off after four minutes if there is no flow. Internal functions continue to run.
- 10 mm high LCD digits
- 6-segment floating point display
- Replaceable batteries (approx. 4000 operating hours) without data loss (data saving in EEPROM).

Model EDM-4... Flow Meter /Counter

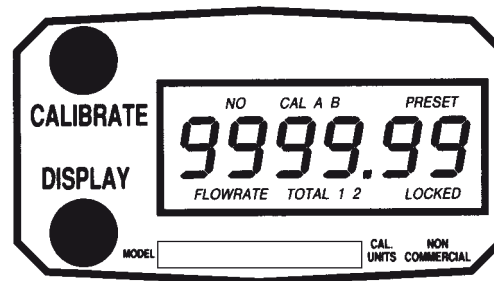

- Local display and actual flow rate (FLOWRATE)
- Total 1: (Total amount) cannot be reset
- Total 2: (Partial amount) can be reset
- CAL A: Factory set calibration for low viscosity media which can not be deleted (low viscosity = max. 25 mm²/s)
- CAL B: Own calibration (in situ calibration) and for liquids up to max. 200 mm²/s



EDM-4... Flow meter and counter

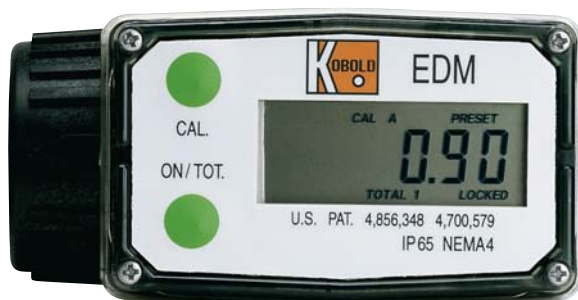

Technical Specifications

- Pressure rating: Nylon max. 10 bar, aluminium max. 20 bar, stainless steel max. 100 bar
- Temperature: -10°C to +60°C
- Protection type: IP 65
- Max. flow rate: 40% > full-scale value
- Pressure loss: max. 0.4 bar at maximum flow rate
- Accuracy: ± 1.5% f. s. (standard calibration); ± 1.0% f. s. for field calibration
- Repeatability: ± 0.1%
- Viscosity: max. 200 mm²/s
- Supply: two lithium batteries (approx. 4000 operating hours), replaceable without data loss

Measuring range (water)	Connection	Order number		
		Aluminium	Nylon	Stainless steel
4 - 40 L/min	Rc 1/2			EDM-4S13
8 - 80 L/min	Rc 3/4	-	-	EDM-4S14
10 - 190 L/min	Rc 1" (G 1)*	EDM-4A12	EDM-4N12	-
20 - 200 L/min	Rc 1"	-	-	EDM-4S15
40 - 400 L/min	Rc 1 1/2"	-	-	EDM-4S16
80 - 800 L/min	Rc 2"	-	-	EDM-4S17

*G thread with aluminium housing

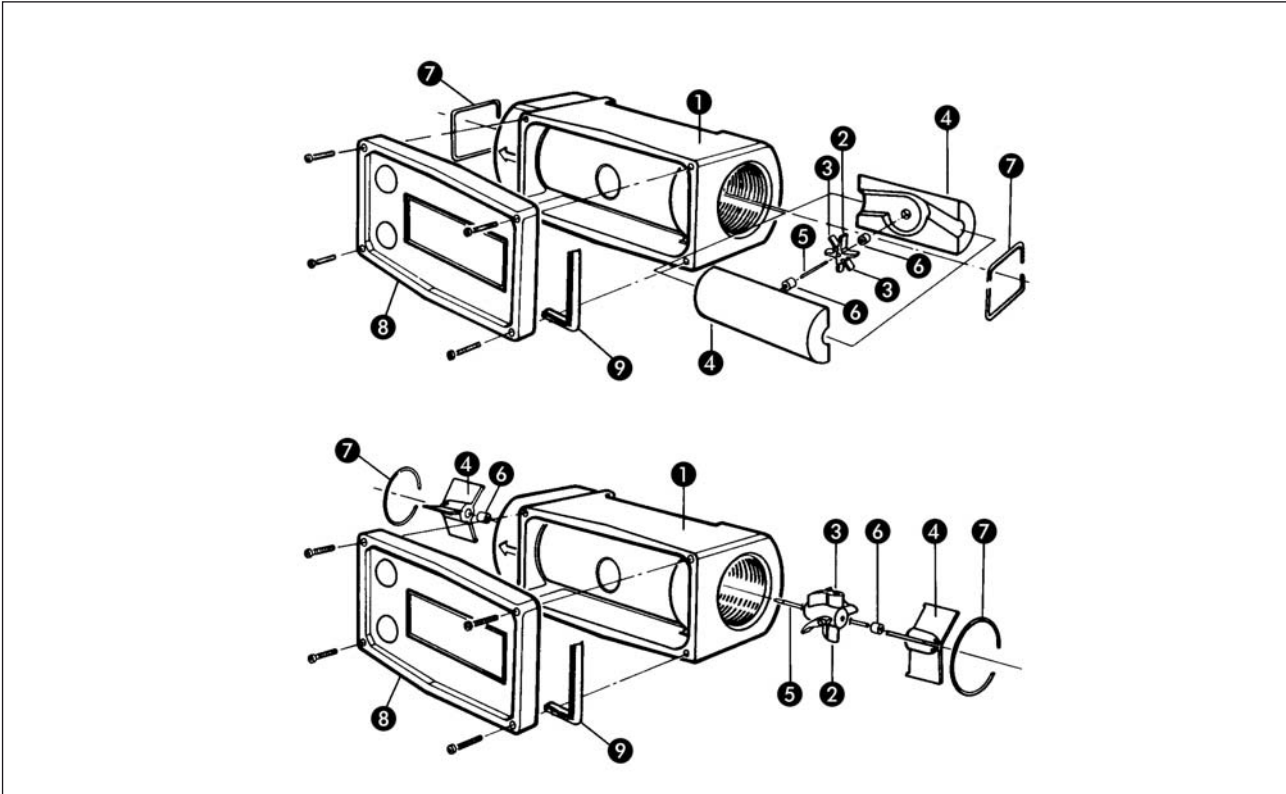

Wetted Part Materials

		Aluminium	Nylon	Stainless steel
	Model	EDM-4A..	EDM-4N..	EDM-4S..
①	Housing	Aluminium	Nylon	st. steel 1.4401 (316 SS)
②	Turbine	Nylon	Nylon	PVDF
③	Pulse generator	Ferrite	Ferrite	Ferrite
④	Mounting	Nylon	Nylon	PVDF
⑤	Axle	Tungsten carbide	Tungsten carbide	Tungsten carbide
⑥	Bearings	Ceramics	Ceramics	Ceramics
⑦	Locking ring	st. steel 1.4401 (316 SS)	st. steel 1.4401 (316 SS)	st. steel 1.4401 (316 SS)
⑧	Electronic housing	Nylon	Nylon	Nylon
⑨	Gasket	Rubber	Rubber	Rubber
	Max. pressure	20 bar	10 bar	100 bar
	Max. temperature	-10 to +60 °C	-10 to +60 °C	-10 to +60 °C

Dimensions and Weight's

		Aluminium	Nylon	Stainless steel
	Model	EDM-4A...	EDM-4N...	EDM-4S...
	Dimensions (LxWxH)	102 x 64 x 51 mm	102 x 64 x 51 mm Nylon Ferrite	1/2": 110 x 50 x 55 mm 1": 115 x 50 x 75 mm 2": 160 x 85 x 100 mm
	Weight	0.37 kg	0.27 kg	1/2": 1.0 kg 1": 1.2 kg 2": 3.2 kg