



Oscillation Flowmeter for gases



measuring
•
monitoring
•
analysing

DOG-1/-3



- Measuring ranges:
0.2 - 20 ... 200 - 20 000 m³/h air
- p_{max}: PN 40; t_{max}: 120°C
- Connection:
flange DN 25 ... DN 400
- Material: cast iron,
steel or stainless steel
- Accuracy: ±1.5 % of measured value
- No moving parts
- Long-term stability



KOBOLD companies worldwide:

ARGENTINA, AUSTRIA, BELGIUM, BULGARIA, CANADA, CHILE, CHINA, COLUMBIA, CZECHIA, DOMINICAN REPUBLIC, EGYPT, FRANCE, GERMANY, GREAT BRITAIN, HUNGARY, INDIA, INDONESIA, ITALY, MALAYSIA, MEXICO, NETHERLANDS, PERU, POLAND, ROMANIA, SINGAPORE, SOUTH KOREA, SPAIN, SWITZERLAND, TAIWAN, THAILAND, TUNISIA, USA, VIETNAM

KOBOLD Messring GmbH
Nordring 22-24
D-65719 Hofheim/Ts.
Head Office:
+49(0)6192 299-0
+49(0)6192 23398
info.de@kobold.com
www.kobold.com



Description

The KOBOLD flowmeter DOG-1 and DOG-3 are used for noncontact flow measurement of gases.

The medium flows through an orifice in a tube. Bypass bores are located at the sides. The dynamic pressure at the orifice causes part of the gas volumetric flow to flow into the bypass. The division ratio remains constant over the whole measuring range.

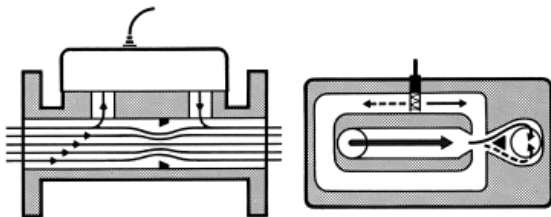

The bypass channel contains the Oscillator – the measuring cell itself. When the gas flows through the measuring cell, a gas column oscillates in a U-shaped channel mounted to the left and right. This oscillation frequency is proportional to the flow velocity and thus to the total volume flow. The oscillation frequency is sensed with a hot wire sensor. An electrical alternating signal is generated that is displayed in the series-connected electronics.

Description

The inner, connected flow channels are generously dimensioned. The constant changes of direction of the flow in the channels have a self-cleaning effect. The devices are therefore extremely dirt resistant and have no consumables. The mounting position can be chosen at will. When condensate forms in the gas, the horizontal mounting position with the sensing element pointing upwards is recommended. The gas flow velocity anywhere in the pipework upstream of the flowmeter should not exceed the sound velocity. Pressure drops above critical and pulsating streams must be avoided. The recommended inlet pipe section is 10xDN and the outlet pipe section 5xDN.

Areas of Application

- Compressed air
- Natural gas, biogas, fermentation gas
- Propane
- Hydrogen gas
- Nitrogen
- Argon

Technical Details

Measuring accuracy: $\pm 1.5\%$ of meas. value (at $Q_t - 100\%*$)
 $\pm 5\%$ of measured value (at $1\% - Q_t*$)
**The lower limit Q_t depends on the density*

- $Q_t = 8\%$ at density 1 kg/m^3
- $Q_t = 4\%$ at density 2 kg/m^3
- $Q_t = 2\%$ at density 4 kg/m^3
- $Q_t = 1\%$ at density $\geq 8 \text{ kg/m}^3$

Repeatability: 0.1% of measured value
 Max. temperature: $-20 \dots +120^\circ\text{C}$
 $-20 \dots +60^\circ\text{C}$ (Ex-Version)

Ambient temperature: max. 80°C
 $-25 \dots +60^\circ\text{C}$ (Ex-Version)

Operating pressure: DOG-11/12..., DOG-31/32...: PN 16
 DOG-12/13..., DOG-32/33...: PN 40

Span: DOG-1...: 1:100
 DOG-3...: 1:50

Sensor: hot-wire, RDC

Pulses: max. 200 Hz

Protection: IP 65

Materials

Case: DOG-11...: cast steel GJL-250
 Wst.No. 0.6025
 DOG-13...: steel P235GH
 DOG-33...: steel S355J2G3
 DOG-12/32...: st. steel 1.4571

Orifice: stainless steel 1.4436

Sensing element: polyphenylene sulfide (PPS)

Sensor: platinum

Gaskets: silicone, nitrile or FPM

Electronics DOG-... E/X

Electrical connection: conduit thread

Protection: IP 65

Display: 4-digit LCD display, counter

Power supply: $230 \text{ V}_{AC} -10\%, +12\% / 48 \dots 62 \text{ Hz}$

Input: hot wire sensor

Pulse output 1: 12 V_{DC} , max.100 mA,
 open collector

Pulse output 2: potential-free contact decadic
 250 V_{AC} , max. 3 A



Analogue output: 4...20 mA
max. 500 Ω

Ambient temperature: 0...+50 °C

Permissible distance: max. 50 m to DOG-1, DOG-3
max. 1000 m to DOG-2

Connection cable: minimum 0.5 mm²,
screening recommended

Ex-Version:  II 1G EEx ia IIC T4

Electronics DOG-...W/Z/Q

for DOG-flowmeters and all meters with pulse detection by means of a proximity switch (model NAMUR)

Electrical connection: terminal

Protection: IP 65

Mounting type: wall mounting

Display: 2 x digits LCD with back-lit display
line 1: flow rate (m³_N/h, m³_N/min, m³/h, m³/min, kg/h, kg/min), 7 digits, floating decimal point
current pressure (barg), only available for option "Q"
line 2: totaliser (m³_N, m³, kg), 12 digits, floating decimal point
current temperature (°C, °F, K), only available for option "Q"

Engineering units are configured at the factory and should thus be mentioned in the P. O. while ordering.

DOG-...W

Built-in 16 point linearization function

Display indication: flow rate/accumulated volume, resettable

Output: pulse, 12 V open collector

DOG-...Z

Built-in 16 point linearization function

Display indication: flow rate/accumulated volume, resettable

Output: pulse, 12 V open collector/4...20 mA, galvanic isolated

DOG-...Q

Built-in 16 point linearization function of the flowmeter signal

Input signal from: (a) gas flowmeter – pulse,
(b) pressure transmitter – 4...20 mA (0–x bar g),
(c) temperature sensor Pt 100

Built-in calculation function for PT correction

Display indication of all process parameters

Output signal: (i) pulse, resettable, for selected units, e.g. m³, m³_N or kg
(ii) 4...20 mA, galvanic isolated, with selected volume or mass units, such as m³/h, m³_N/h or kg/h

Input signal (pulse train)

Flowmeter DOG: directly

Proximity switch: max 8 V_{DC} (high level)

Speed range: 0...500 Hz

Over voltage protection: 24 V

Input signal (analogue)

Temperature sensor: Pt 100 (four wire lead comp.)

Pressure transducer: 4...20 mA

Basic measuring resolution: 12 bit

Accuracy: 0.05 % at 20 °C

Update rate: 1 update/sec

Reverse polarity: no ill effects

Over current limit: 12 V_{DC}, 100 mA (fault protected)

Output signal

(i) pulse train assignable to uncompensated or PT compensated volume total, or mass total
12 V_{DC} active (voltage pulse)
alt. passive (open collector, max 24 V_{DC} load)
pulse width adjustable

(ii) isolated analogue output signal 4...20 mA
assignable to uncompensated or PT compensated flow rate

Accuracy: 0.1% of full scale at 20 °C

Update rate: 5 updates/sec

Maximum load: 500 Ω



Order Details for DOG-1 with flange (Example: DOG-1101L F25N S E)

Measuring range air [m³/h]	Model			Connection flange		Gasket	Remote electronics
	Material cast iron	Material steel	Material st. steel	Standard PN 16 only GG, VA	Special PN 40 only steel, st. steel		
0.2...20 0.35...35 0.7...70	DOG-1101L.. DOG-1102L.. DOG-1103L..	- - -	DOG-1201L.. DOG-1202L.. DOG-1203L..	F25N = DN25	F25S = DN25	S = silicone N = nitrile V = FPM	with external electronics ...E RDC input, without display, with EX protection, with analogue and pulse output ...X RDC input, with display for instantaneous value and total, with EX protection, with analogue and pulse output ...W** display: flow/total resettable ...Z** display: flow/total resettable, 4...20 mA ...Q** flow calculator, input: pulse, Pt 100, 4...20 mA (pressure) output: 4...20 mA
0.2...20 0.6...60 1.0...100	- - -	DOG-1304L.. DOG-1305L.. DOG-1306L..	- - -	F32N = DN32	F32S = DN32		
0.2...20 0.9...90 2.0...200	DOG-1107L.. DOG-1108L.. DOG-1109L..	- - -	DOG-1207L.. DOG-1208L.. DOG-1209L..	F40N = DN40	F40S = DN40		
0.2...20 1.1...110 2.5...250	DOG-1110L.. DOG-1111L.. DOG-1112L..	- - -	DOG-1210L.. DOG-1211L.. DOG-1212L..	F50N = DN50	F50S = DN50		
0.9...90 1.7...170 4.5...450	- - -	DOG-1313L.. DOG-1314L.. DOG-1315L..	DOG-1213L.. DOG-1214L.. DOG-1215L..	F65N = DN65	F65S = DN65		
1.4...140 4.5...450 8.0...800	DOG-1116L.. DOG-1117L.. DOG-1118L..	- - -	DOG-1216L.. DOG-1217L.. DOG-1218L..	F80N = DN80	F80S = DN80		
2.7...270 6.5...650 10...1000	DOG-1119L.. DOG-1120L.. DOG-1121L..	- - -	DOG-1219L.. DOG-1220L.. DOG-1221L..	F1HN = DN100	F1HS = DN100		
4...400 8...800 15...1500	- - -	DOG-1322L.. DOG-1323L.. DOG-1324L..	DOG-1222L.. DOG-1223L.. DOG-1224L..	F1ZN = DN125	F1ZS = DN125		
6...600 12...1200 30...3000	- - -	DOG-1325L.. DOG-1326L.. DOG-1327L..	DOG-1225L.. DOG-1226L.. DOG-1227L..	F1FN = DN150	F1FS = DN150		
12...1200 25...2500 60...6000	- - -	DOG-1328L.. DOG-1329L.. DOG-1330L..	DOG-1228L.. DOG-1229L.. DOG-1230L..	F2HN = DN200	F2HS = DN200		
20...2000 40...4000 75...7500	- - -	DOG-1331L.. DOG-1332L.. DOG-1333L..	DOG-1231L.. DOG-1232L.. DOG-1233L..	F2FN = DN250	F2FS = DN250*		
30...3000 50...5000 113...13000	- - -	DOG-1334L.. DOG-1335L.. DOG-1336L..	- - -	F3HN = DN300	F3HS = DN300		
40...4000 70...7000 140...14000	- - -	DOG-1337L.. DOG-1338L.. DOG-1339L..	- - -	F3FN = DN350	-		
50...5000 100...10000 160...16000	- - -	DOG-1340L.. DOG-1341L.. DOG-1342L..	- - -	F4HN = DN400	-		

* not for DOG-12 (stainless steel)

** Engineering units are configured at the factory and should thus be mentioned in the P.O. while ordering

Please state the exact operating conditions (gas types, flow volume, pressure, temperature, installation position etc.) when ordering.



Order Details for DOG-3 with flange (Example: DOG-3301L F25N S E)

Measuring range air [m³/h]	Model		Connection flange		Gasket	Remote electronics
	Material steel	Material st. steel	Standard PN 16 only GG, VA	Special PN 40 only steel, st. steel		
0.4...20 0.7...35 1.4...70	DOG-3301L.. DOG-3302L.. DOG-3303L..	DOG-3201L.. DOG-3202L.. DOG-3203L..	F25N = DN25	F25S = DN25	S = silicone N = nitrile V = FPM	with external electronics ...E RDC input, without display, with EX protection, with analogue and pulse output ...X RDC input, with display for instantaneous value and total, with EX protection, with analogue and pulse output ...W* display: flow/total resettable ...Z* display: flow/total resettable, 4...20 mA ...Q* flow calculator, input: pulse, Pt 100, 4...20 mA (pressure) output: 4...20 mA
0.4...20 1.8...90 3.5...180	DOG-3307L.. DOG-3308L.. DOG-3309L..	DOG-3207L.. DOG-3208L.. DOG-3209L..	F40N = DN40	F40S = DN40		
0.4...20 2.2...105 5...250	DOG-3310L.. DOG-3311L.. DOG-3312L..	DOG-3210L.. DOG-3211L.. DOG-3212L..	F50N = DN50	F50S = DN50		
1.8...90 3.5...170 9...450	DOG-3313L.. DOG-3314L.. DOG-3315L..	DOG-3213L.. DOG-3214L.. DOG-3215L..	F65N = DN65	F65S = DN65		
2.8...135 6...300 16...800	DOG-3316L.. DOG-3317L.. DOG-3318L..	DOG-3216L.. DOG-3217L.. DOG-3218L..	F80N = DN80	F80S = DN80		
6...300 14...700 18...900	DOG-3319L.. DOG-3320L.. DOG-3321L..	DOG-3219L.. DOG-3220L.. DOG-3221L..	F1HN = DN100	F1HS = DN100		
8...400 18...900 40...2000	DOG-3322L.. DOG-3323L.. DOG-3324L..	DOG-3222L.. DOG-3223L.. DOG-3224L..	F1ZN = DN125	F1ZS = DN125		
12...600 25...1250 60...3000	DOG-3325L.. DOG-3326L.. DOG-3327L..	DOG-3225L.. DOG-3226L.. DOG-3227L..	F1FN = DN150	F1FS = DN150		
24...1200 50...2500 30...3000	DOG-3328L.. DOG-3329L.. DOG-3330L..	DOG-3228L.. DOG-3229L.. DOG-3230L..	F2HN = DN200	F2HS = DN200		
40...2000 80...4000 150...7500	DOG-3331L.. DOG-3332L.. DOG-3333L..	DOG-3231L.. DOG-3232L.. DOG-3233L..	F2FN = DN250	F2FS = DN250		
60...3000 100...5000 240...12000	DOG-3334L.. DOG-3335L.. DOG-3336L..	DOG-3234L.. DOG-3235L.. DOG-3236L..	F3HN = DN300	F3HS = DN300		
80...4000 140...7000 280...14000	DOG-3337L.. DOG-3338L.. DOG-3339L..	DOG-3237L.. DOG-3238L.. DOG-3239L..	F3FN = DN350	F3FS = DN350		
100...5000 200...10000 400...20000	DOG-3340L.. DOG-3341L.. DOG-3342L..	DOG-3240L.. DOG-3241L.. DOG-3242L..	F4HN = DN400	F4HS = DN400		

* Engineering units are configured at the factory and should thus be mentioned in the P.O. while ordering

Please state the exact operating conditions (gas types, flow volume, pressure, temperature, installation position etc.) when ordering.

Pressure Loss/Flow

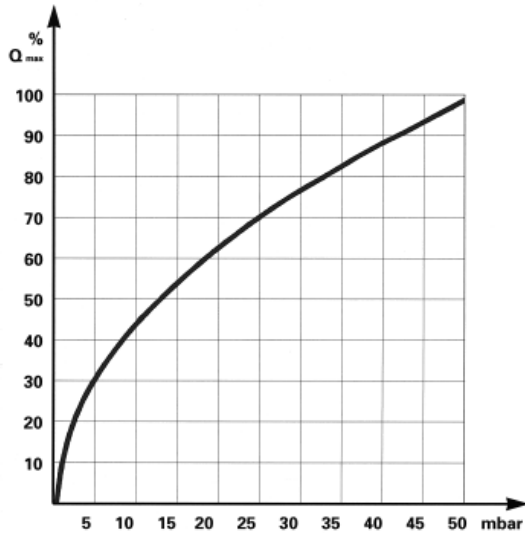

The diagram applies for gases with a density of air at NPT (0°C and 1000 mbar). The pressure loss is always proportional to the density of the gas. For example, the pressure loss doubles at 100% higher operating pressure.

Calculating the Actual Density

The actual density can be calculated with the following formula:

$$D = \frac{D_0 \cdot P \cdot T_0}{T}$$

D_0 = density at 1 bar abs. and 0°C (= 273 K)

T = temperature in K

(= °C + 273 for example 20°C = 273 + 20 = 293 K)

T_0 = 273 K

P = operating pressure in bar (absolute pressure)

Calculating the Norm Flow

$$Q_N = Q \cdot \frac{P \cdot 273}{1.013 \cdot T}$$

Q_N = norm flow at 1.013 bar abs. and 0°C

Q = operating flow

P = operating pressure in bar (absolute pressure)

T = operating temperature in K

Dimensions and Weight DOG-1

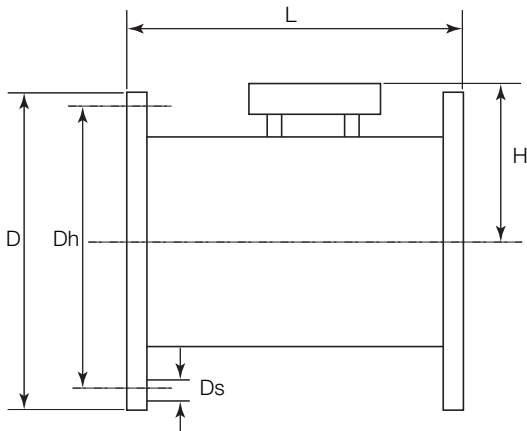

DN [mm]	L [mm]	D [mm]	Dh [mm]	Ds [mm]	Number of holes	H [mm]	H with AVF [mm]	Weight [kg]
25	300	115	85	14	4	130	165	10
32	300	140	100	18	4	140	175	11
40	300	150	110	18	4	140	175	12
50	300	165	125	18	4	145	180	13
65	300	185	145	18	4	155	190	14
80	300	200	160	18	8	160	195	20
100	300	220	180	18	8	200	235	23
125	300	250	210	18	8	230	265	20
150	350 or 500	285	240	22	8	255	290	26, 28
200	350	340	295	22	12	280	315	36
250	450	405	355	26	12	305	340	53
300	500	460	410	26	12	330	365	70
350	500	520	470	26	16	360	395	83
400	500	580	525	30	16	380	415	90

Dimensions and Weight DOG-3

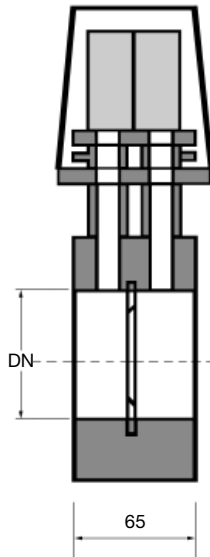

Dimensions of Electronics DOG-...E/X

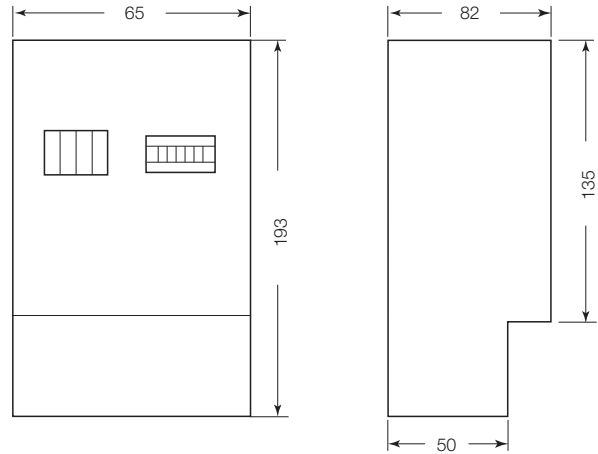

DN [mm]	D [mm]	Weight [mm]
25	65	10
32	65	11
40	65	12
50	65	13
65	65	14
80	65	20
100	65	23
125	65	20
150	65	28
200	65	36
250	65	53
300	65	70
350	65	90
400	65	120

Dimensions of Electronics DOG-...W/Z/Q

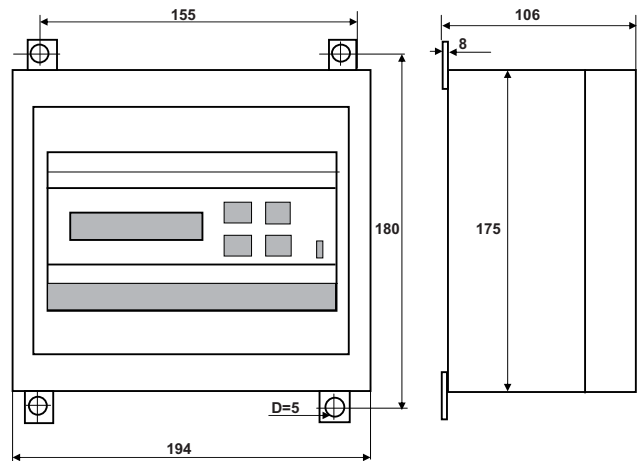

Accessory

Valve in the bypass (between measuring tube and measuring cell) for easy sensor changing and for protection of the sensor when starting the installation.



Oscillation Flowmeter for liquids



measuring
•
monitoring
•
analysing

DOG-2

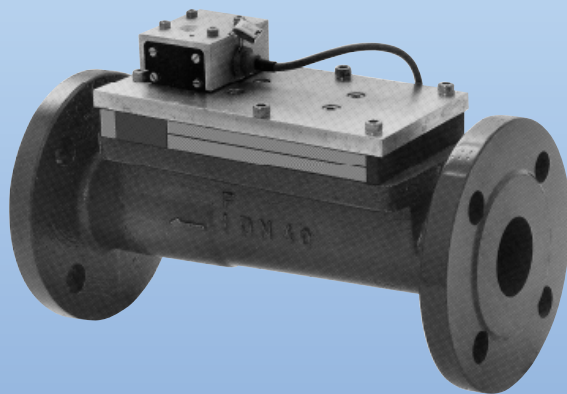

- Measuring ranges:
0.075-3.75 ... 70-3500 m³/h water
- p_{max}: PN 40; t_{max}: 120°C
- Connection:
flange DN 25 ... DN 400
- Material: cast iron,
steel or stainless steel
- Accuracy: ±0.5 % of measured value
- No moving parts
- Long-term stability



KOBOLD companies worldwide:

ARGENTINA, AUSTRIA, BELGIUM, BULGARIA, CANADA, CHILE, CHINA, COLUMBIA, CZECHIA, DOMINICAN REPUBLIC, EGYPT, FRANCE, GERMANY, GREAT BRITAIN, HUNGARY, INDIA, INDONESIA, ITALY, MALAYSIA, MEXICO, NETHERLANDS, PERU, POLAND, ROMANIA, SINGAPORE, SOUTH KOREA, SPAIN, SWITZERLAND, TAIWAN, THAILAND, TUNISIA, USA, VIETNAM

KOBOLD Messring GmbH
Nordring 22-24
D-65719 Hofheim/Ts.
Head Office:
+49(0)6192 299-0
+49(0)6192 23398
info.de@kobold.com
www.kobold.com

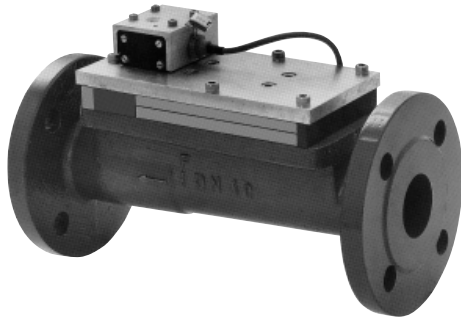

Description

The KOBOLD flowmeter DOG-2 is used for non-contact flow measurement of low viscosity liquids.

The medium flows through an orifice in a tube and side bypass bores. The dynamic pressure at the orifice causes part of the liquid to flow through the bypass. The division ratio remains constant over the whole measuring range.

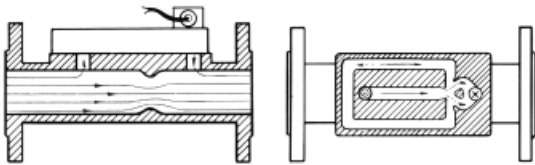

The bypass channel contains the Oscillator – the measuring cell itself. When the medium flows through the measuring cell, a liquid column oscillates in a U-shaped channel mounted to the left and right. This oscillation frequency is proportional to the flow velocity.

A chamber with a hollow ball is situated over this channel. It is connected with the lower channel by two bore holes. The oscillation of the liquid column is thus transferred to the ball, which in turn moves back and forth with the same frequency. The ball movement is sensed by an initiator. An electrical alternating signal is generated that is displayed in the series-connected electronics.

Application

The inner, connected flow channels are generously dimensioned. The constant changes of direction of the flow in the channels have a self-cleaning effect. The devices are therefore extremely dirt resistant and have no consumables. The mounting position can be chosen at will. When the liquid contains air bubbles, the vertical mounting position with the sensing element pointing upwards is recommended. To avoid air bubbles the device should not be mounted at the highest point in a plant. Pulsating flow must be avoided.

The recommended inlet pipe section is 10xDN and the outlet pipe section 5xDN.

Areas of Application

- Hot water in district heat supply
- Non-conductive liquid

Technical Details

Measuring accuracy:	$\pm 0.5\%$ of measured value (5...100%*) $\pm 2\%$ of measured value (at 2...5%) <i>*These values relate to viscosities of ≤ 1 mm²/s</i>
Repeatability:	0.2% of measured value
Temperature:	max. 0 to +120 °C
Ambient temperature:	max. 60 °C
Operating pressure:	DOG-21...: PN 16 DOG-22..., DOG-24...: PN 40
Span:	1: 50 (1 mm ² /s) 1:70 (at 0.5 mm ² /s) per 1 mm ² /s halved by the span
Max. viscosity:	3 mm ² /s sensor
Connection:	cable, 2 m PVC, blue
Protection:	IP 65

Materials

Case:	DOG-21...: cast steel GJL-250 Wst.No. 0.6025 DOG-22...: steel S355J2G3 DOG-24...: st. steel 1.4571
Orifice:	stainless steel 1.4436
Sensing element:	polyphenylene sulfide (PPS)
Sensor:	hollow ball proximity, high temperature
Gaskets:	standard: EPDM and silicone option: FPM, nitrile

Without electronics with pulse output

Initiator, 5...8 V_{DC}, 3 mA,
high 5 V_{DC}, low 3 V_{DC}

Electronics DOG-...W/Z

for DOG-flowmeters and all meters with pulse detection by means of a proximity switch (model NAMUR)

Electrical connection: terminal

Protection: IP 65

Mounting type: wall mounting

Display: 2 x digits LCD with back-lit display
 line 1: flow rate (m^3_N/h , m^3_N/min , m^3/h , m^3/min , kg/h , kg/min), 7 digits, floating decimal point
 line 2: totaliser (m^3_N , m^3 , kg), 12 digits, floating decimal point

Engineering units are configured at the factory and should thus be mentioned in the P.O. while ordering.

DOG-...W

Built-in 16 point linearization function

Display indication: flow rate/accumulated volume, resettable

Output: pulse, 12 V open collector

DOG-...Z

Built-in 16 point linearization function

Display indication: flow rate/accumulated volume, resettable

Output: pulse, 12 V open collector/4...20 mA, galvanic isolated



Input signal (pulse train)

Flowmeter DOG: directly
 Proximity switch: max 8 V_{DC} (high level)
 Speed range: 0...500 Hz
 Over voltage protection: 24 V

Output signal

- (i) pulse train assignable to uncompensated or PT compensated volume total, or mass total
 12 V_{DC} active (voltage pulse)
 alt. passive (open collector, max 24 V_{DC} load)
 pulse width adjustable
 - (ii) isolated analogue output signal 4...20 mA
 assignable to uncompensated or PT compensated flow rate
- Accuracy: 0.1% of full scale at 20°C
 Update rate: 5 updates/sec
 Maximum load: 500 Ω



Oscillation Flowmeter Model DOG-2

Order Details (Example: DOG-2101L F25N N F)

Measuring range water [m³/h]	Model			Connection flange		Gasket	Remote electronics
	Material cast iron	Material steel	Material st. steel	Standard PN16 only GG, VA	Special PN 40 only steel, st. steel		
0.075 ... 3.75 0.13 ... 6.6 0.2 ... 10	DOG-2101L.. DOG-2102L.. DOG-2103L..	- - -	DOG-2201L.. DOG-2202L.. DOG-2203L..	F25N = DN 25	F25S = DN 25	N = nitrile V = FPM E = EPDM (standard)	Frequency output without electronics ...F Initiator, 5...8 V _{DC} , 3 mA, high 5 V _{DC} , low 3 V _{DC}
0.08 ... 4 0.16 ... 8 0.3 ... 15	- - -	DOG-2304L.. DOG-2305L.. DOG-2306L..	- - -	F32N = DN 32	F32S = DN 32		
0.12 ... 6 0.28 ... 14 0.6 ... 30	DOG-2107L.. DOG-2108L.. DOG-2109L..	- - -	DOG-2207L.. DOG-2208L.. DOG-2209L..	F40N = DN 40	F40S = DN 40		
0.26 ... 13 0.56 ... 28 0.96 ... 48	DOG-2110L.. DOG-2111L.. DOG-2112L..	- - -	DOG-2210L.. DOG-2211L.. DOG-2212L..	F50N = DN 50	F50S = DN 50		
0.39 ... 19.6 0.76 ... 38 1.5 ... 75	- - -	DOG-2313L.. DOG-2314L.. DOG-2315L..	DOG-2213L.. DOG-2214L.. DOG-2215L..	F65N = DN 65	F65S = DN 65		
0.46 ... 23 1.32 ... 66 2.6 ... 130	DOG-2116L.. DOG-2117L.. DOG-2118L..	- - -	DOG-2216L.. DOG-2217L.. DOG-2218L..	F80N = DN 80	F80S = DN 80		
1.2 ... 60 2 ... 100 3.2 ... 160	DOG-2119L.. DOG-2120L.. DOG-2121L..	- - -	DOG-2219L.. DOG-2220L.. DOG-2221L..	F1HN = DN 100	F1HS = DN 100		
1.4 ... 70 2.6 ... 130 5 ... 250	- - -	DOG-2322L.. DOG-2323L.. DOG-2324L..	DOG-2222L.. DOG-2223L.. DOG-2224L..	F1ZN = DN 125	F1ZS = DN 125		
1.9 ... 94 4 ... 200 10 ... 500	- - -	DOG-2325L.. DOG-2326L.. DOG-2327L..	DOG-2225L.. DOG-2226L.. DOG-2227L..	F1FN = DN 150	F1FS = DN 150		
3.4 ... 170 6.8 ... 340 19.6 ... 980	- - -	DOG-2328L.. DOG-2329L.. DOG-2330L..	DOG-2228L.. DOG-2229L.. DOG-2230L..	F2HN = DN 200	F2HS = DN 200		
5.2 ... 2000 11 ... 550 25 ... 1255	- - -	DOG-2331L.. DOG-2332L.. DOG-2333L..	DOG-2231L.. DOG-2232L.. DOG-2233L..	F2FN = DN 250	F2FS = DN 250*		
6 ... 300 16 ... 800 40 ... 2000	- - -	DOG-2334L.. DOG-2335L.. DOG-2336L..	- - -	F3HN = DN 300	F3HS = DN 300		
8 ... 420 19 ... 970 150 ... 2700	- - -	DOG-2337L.. DOG-2338L.. DOG-2339L..	- - -	F3FN = DN 350	F3FS = DN 350		
13 ... 650 26 ... 1300 170 ... 3500	- - -	DOG-2340L.. DOG-2341L.. DOG-2342L..	- - -	F4HN = DN 400	F4HD = DN 400		

* not for DOG-22 (stainless steel)

** Engineering units are configured at the factory and should thus be mentioned in the P.O. while ordering

Please state the exact operating conditions (gas types, flow volume, pressure, temperature, installation position etc.) when ordering.

Pressure Loss/Flow

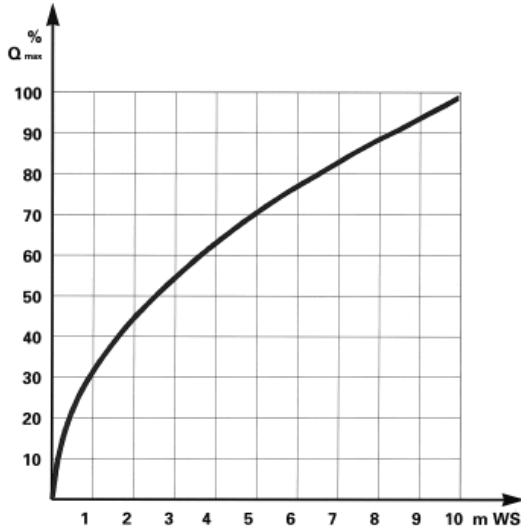

Dimensions of Electronics DOG-...W/Z

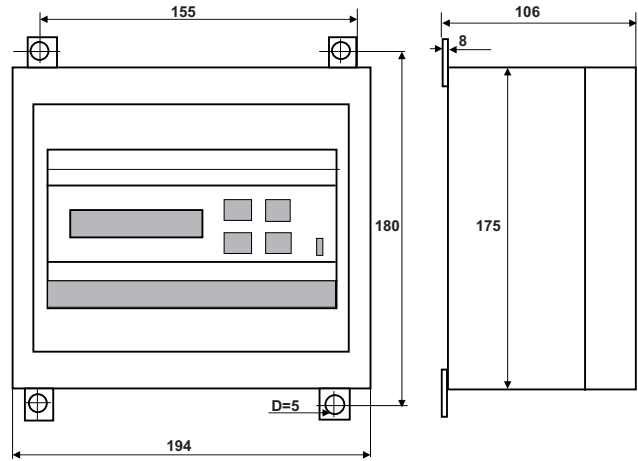

Transducer

Dimensions and Weight

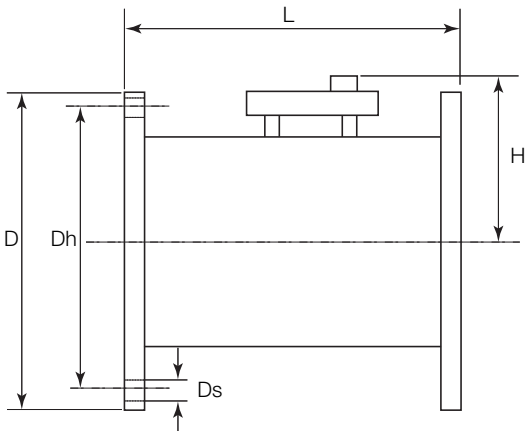

DN [mm]	L [mm]	D [mm]	Dh [mm]	Ds [mm]	Number of holes	H [mm]	H with AVF [mm]	Weight [kg]
25	260	115	85	14	4	110	145	10
32	260	140	100	18	4	115	150	11
40	300	150	110	18	4	120	155	12
50	270	165	125	18	4	125	160	13
65	300	185	145	18	4	135	170	14
80	300	200	160	18	8	140	175	20
100	360	220	180	18	8	180	215	23
125	300	250	210	18	8	215	250	20
150	350 or 500	285	240	22	8	235	270	26, 28
200	350	340	295	22	12	260	295	36
250	450	405	355	26	12	285	315	53
300	500	460	410	26	12	310	345	70
350	500	520	470	26	16	340	375	83
400	500	580	525	30	16	360	395	90