



Vortex Flow Meter



measuring
•
monitoring
•
analysing

DVH



- Measuring range:
3-8 ... 3057 - 280 187 m³_N/h
- Accuracy:
±0,7 % of reading (liquids)
±1 % of reading (gases and steam)
- p_{max}: 100 bar abs; t_{max}: 400 °C
- Connection: ANSI 1/2" up to ANSI 8",
DN 15 up to DN 200
- Material: stainless steel
- Output: 4 - 20 mA, HART® Protocol
- **Sensor design without sealing**
- **Integrated temperature and pressure measurement**
- **Measurement of mass and density possible**
- ATEX, IEC Ex



KOBOLD companies worldwide:

ARGENTINA, AUSTRIA, BELGIUM, BULGARIA, CANADA, CHILE, CHINA, COLUMBIA, CZECHIA, DOMINICAN REPUBLIC, EGYPT, FRANCE, GERMANY, GREAT BRITAIN, HUNGARY, INDIA, INDONESIA, ITALY, MALAYSIA, MEXICO, NETHERLANDS, PERU, POLAND, ROMANIA, SINGAPORE, SOUTH KOREA, SPAIN, SWITZERLAND, TAIWAN, THAILAND, TUNISIA, USA, VIETNAM

KOBOLD Messring GmbH
Nordring 22-24
D-65719 Hofheim/Ts.
Head Office:
+49(0)6192 299-0
+49(0)6192 23398
info.de@kobold.com
www.kobold.com

Despriction

The KOBOLD Vortex Flowmeter DVH utilizes three primary sensing elements: **a vortex shedding velocity sensor, a RTD temperature sensor and a solid-state pressure transducer** to measure the mass flow rate of gases, liquids and steam.

Systems that use external process measurements may not provide adequate compensation for the fact that process conditions can change radically between the point of velocity measurement and the point where upstream or downstream pressure and temperature measurements are being made.

Because the DVH multivariable flow meter measures all of these parameters in **a single location**, it delivers a more accurate process measurement.

Integrating multivariable output capability with a single line penetration also simplifies system complexity and helps reduce initial equipment cost, installation cost and maintenance costs.

Advantages of the DVH Vortex Flow Meter

- DVH-V provides cost effective volumetric flow monitoring solution for most liquids
- DVH-T incorporates temperature sensing to provide a compensated mass flow reading of saturated steam
- DVH-P multivariable meter delivers mass flow, temperature, pressure and density readings
- Connections: ANSI 1/2" up to ANSI 8", DN 15 up to DN 200
- Easy to install and commission
- Field- configurable ranges, outputs and displays
- HART® Protocol
- FM-approved, IEC Ex / ATEX

Measuring principle

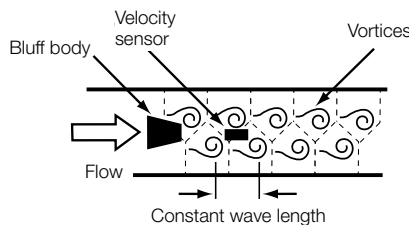

The measuring principle is based on the Karman vortice street. A specially shaped bluff body is located in direction of the flow. From a certain flow velocity on vortices are generated through the bluff body.

This small vortices generate small pressure differences which are sensed from a piezoelectric sensor behind.

The number of vortices is directly proportional to the flow velocity and will be provided to an evaluating electronic.

Model DVH-V

The Model DVH-V delivers a direct reading of volumetric flow rate - generally the most costeffective solution for liquid flow monitoring - in applications ranging from general water flows to hydrocarbon fuel flow measurement.

Model DVH-T

The Model DVH-T integrates a precision 1000 Ω platinum RTD temperature sensor that can be used to calculate and output a compensated mass reading. This device is typically used to measure flow rates of saturated steam.

Model DVH-P

The Model DVH-P offers you flow computer functionality in a compact field device. This multivariable instrument incorporates temperature and pressure sensors to provide an instantaneous reading of compensated mass flow rate of gases, liquids and steam. In addition to outputs for totalized mass and alarm settings, the field-configurable electronics deliver up to three analog (4 - 20 mA) outputs of five process measurements, including volumetric flow rate, mass flow rate, pressure and density.

Model DVH-E

The Model DVH-E Energy Monitoring option permits real-time calculation of energy consumption for a facility or process. The meter can be programmed to measure steam, hot water or chilled water.

The flow meter DVH-E monitors one side of the process, either sent or return, and uses the input from a second separate temperature sensor on the opposite leg of the process to calculate the change in energy. (Not approved for custody transfer applications.)

Selectable energy units include:

Btu, joules, calories, Watthours, Megawatt-hours and Horsepower-hours.

The local or remote electronics indicates: temperature, delta T, mass total and energy total.

Technical Details

Mass flow rate accuracy: for gas and steam based on 50-100 % of pressure range

Model DVH Accuracy

Process variables	Liquids	Gas/Steam
Volumetric Flow Rate	± 0.7 % of rate	± 1 % of rate
Mass Flow Rate	± 1 % of rate	± 1,5 % of rate
Temperature	± 1 °C ; ± 2 °F	± 1 °C ; ± 2 °F
Pressure	± 3 % of full scale	± 0.3 % of full scale
Density	± 0.3 % of reading	± 0.5 % of reading

Repeatability

- Mass Flow Rate: ± 0.2 % of rate
- Volumetric Flow Rate: ± 0.1 % of rate
- Temperature: ± 0.1 °C, ± 0.2 °F
- Pressure: ± 0.5 % of full scale
- Density: ± 0.1 % of reading



Technical Details (continued)

Stability over 12 Month

Mass Flow Rate: ± 0.2 % of rate
 Volumetric
 Flow Rate: ± negligible
 Temperature: ± 0.5 °C, ± 0.9 °F
 Pressure: ± 0.1 % of full scale
 Density: ± 0.1 % of reading
 Response time: adjustable from 1 to 100 s

Process and Ambient Temperature

Standard: -40 to 260 °C, -40 to 500 °F
 High Temperature: up to 400 °C, 750 °F
 Ambient temperature: -20 to 60 °C, -5 to 140 °F
 Storage temperature: -40 to 65 °C, -40 to 150 °F

Max. Operating Pressure		Max. Overload pressure	
psia	bar abs	psia	bar abs
30	2	60	4
100	7	200	14
300	20	600	40
500	35	100	70
1500	100	2500	175

Auxiliary Energy

Model DVH-V: 12-36 V_{DC}, loop powered
 Model DVH-P, DC option: 12-36 V_{DC}, 100 mA max
 Model DVH-P, AC option: 85-240 V_{AC}, 50/60Hz, 2 Watt
 Display: alphanumeric 2-line (16 characters)
 digital LCD Display
 rotateable in 90° steps
 Buttons: Six buttons for full field configuration
 The pushbuttons can be operated with magnetic wand without removal of enclosure covers.

Output signals

Analogue: 4-20 mA loop powered for volumetric meters
 Alarm: solid state relay 40 V_{DC}
 Totalizer pulse: 50 ms 40 V_{DC}
 Volumetric: 1x analogue, 1x totalizer pulse, HART®
 Multivariable: up to 3 analog signals
 3 alarms,
 1 totalizer pulse, HART®
 Option: Modbus process monitoring

Wetted Materials

Material: stainless steel 1.4404 (316L)
 Models with pressure transducer: Dupont Teflon® based thread sealant
 Version Standard temperature: Dupont Teflon® packing
 High temperature: Graphit based packing

Piping Conditions

Conditions	Pipe Diameters D	
	Upstream	Downstream
one 90° elbow before meter	10 D	5 D
two 90° elbows before meter	15 D	5 D
two 90° elbows before meter (out of plane)	25 D	5 D
Reduction before meter	10 D	5 D
Expansion before meter	20 D	5 D
Partially open valve	25 D	5 D

Velocity Range

Liquids

Maximum velocity: 9 m/s (30 ft/s)
 Minimum velocity: 0.3 m/s (1 ft/s)

Gas/stream

Maximum velocity: 90 m/s (300 ft/s)
 Minimum velocity: $\frac{6,1}{\sqrt{\text{Density} \left(\frac{\text{kg}}{\text{m}^3}\right)}}$ $\frac{5}{\sqrt{\text{Density} \left(\frac{\text{Lb}}{\text{ft}^3}\right)}}$

Water Minimum and Maximum Flow Rates

DN (mm)	Nominal Pipe size (mm)								
	10	20	25	40	50	80	100	150	200
m ³ /hr min.	0.2	0.3	0.5	1.3	2.1	4.7	8.1	18	32
m ³ /hr max.	5	9	15	38	63	140	244	554	970
DN (in)	Nominal Pipe size (in)								
	½	¾	1	1½	2	3	4	6	8
GPM min.	0.9	1.4	2.2	5.5	9.2	21	36	81	142
GPM max.	22	40	67	166	276	618	1076	2437	4270

Approvals

ATEX: II 2 G Ex d IIB + H₂ T6
 II 2 D Ex tDA21 IP66 T85 °C
 Ta = -40 °C ... +60 °C
 IEC EX: Ex d IIB + H₂ T6
 Ex tD A21 IP 66 T85 °C, Ta = -40 °C ... +60 °C



Vortex Flow Meter Model DVH

Turndown:

(Turndown is application dependent, can exceed 100:1)

Typical Saturated Steam Minimum and Maximum Flow Rates										
Unit: (kg/h)										
Nominal Pipe Size (mm)										
Pressure		15	20	25	40	50	80	100	150	200
0 bar rel	min.	3	5	8	19	32	72	126	286	500
	max.	18	42	91	224	375	838	1459	3309	5797
5 bar rel	min.	6	11	18	45	75	167	290	658	1153
	max.	95	224	485	1192	1992	4455	7754	17581	30799
10 bar rel	min.	8	15	24	59	99	222	387	877	1537
	max.	168	397	862	2118	3639	7915	13777	31237	54720
15 bar rel	min.	9	17	29	71	119	266	463	1050	1840
	max.	241	569	1236	3036	5073	11347	19750	44779	78444
20 bar rel	min.	11	20	33	81	136	266	529	1199	2100
	max.	314	742	1610	3956	6611	14787	25738	58355	102226
30 bar rel	min.	13	24	40	99	165	369	642	1455	2548
	max.	463	1092	2370	5822	9729	21763	37880	85884	150451

Typical Air Minimum and Maximum Flow Rates (20 °C)										
Unit: (m ³ _N /h)										
Nominal Pipe Size (mm)										
Pressure		15	20	25	40	50	80	100	150	200
0 bar rel	min.	3	5	9	21	36	79	138	313	549
	max.	28	66	142	350	584	1307	2275	5157	9034
5 bar rel	min.	7	13	21	52	87	194	337	764	1339
	max.	165	390	847	2080	3476	7775	13533	30682	53749
10 bar rel	min.	9	17	29	70	117	262	457	1035	1814
	max.	304	716	1554	3819	6381	14273	24844	56329	98676
15 bar rel	min.	11	21	34	85	142	317	551	1250	2190
	max.	442	1044	2265	5565	9299	20801	36205	82087	143801
20 bar rel	min.	13	24	40	97	162	363	632	1434	2511
	max.	582	1373	2979	7318	12229	27354	47612	107949	189105
30 bar rel	min.	16	29	48	118	198	442	770	1745	3057
	max.	862	2034	4414	10843	18119	40529	70544	159942	280187



Turndown (continued):

(Turndown is application dependent, can exceed 100:1)

Typical Air Minimum and Maximum Flow Rates (70 °F)										
Unit: (SCFM)										
Nominal Pipe Size (in)										
Pressure		0.5	0.75	1	1.5	2	3	4	6	8
0 psig	min.	1.8	3	5	13	22	50	87	198	247
	max.	18	41	90	221	369	826	1437	3256	5708
100 psig	min.	5	9	15	38	63	141	245	555	972
	max.	138	325	704	1730	2890	6466	11254	25515	44698
200 psig	min.	7	13	21	52	86	193	335	761	1332
	max.	258	609	1322	3248	5427	12140	21131	47911	83931
300 psig	min.	8	15	25	63	104	234	407	922	1615
	max.	380	896	1944	4775	7978	17847	31064	70431	123375
400 psig	min.	10	18	29	72	120	269	467	467	1857
	max.	502	1183	2568	6309	10542	23580	41043	41043	163000
500 psig	min.	11	20	33	80	134	300	521	1182	2071
	max.	624	1472	3195	7849	13115	28034	51063	11575	203000

Typical Saturated Steam Minimum and Maximum Flow Rates										
Unit: (lb/h)										
Nominal Pipe Size (in)										
Pressure		0.5	0.75	1	1.5	2	3	4	6	8
5 psig	min.	6.5	12	20	49	82	183	318	722	1264
	max.	52	122	265	650	1087	2431	4231	9594	16806
100 psig	min.	15	27	46	112	187	419	728	1652	2893
	max.	271	639	1386	3405	5690	12729	22156	50233	87998
200 psig	min.	20	37	62	151	253	565	983	2229	3905
	max.	493	1163	2525	6203	10365	23184	40354	91494	160279
300 psig	min.	24	45	74	182	304	680	1184	2685	4704
	max.	716	1688	3664	9000	15040	33642	58556	132763	232575
400 psig	min.	28	51	85	209	349	780	1358	3079	5393
	max.	941	2220	4816	11831	19770	44222	76971	174516	305717
500 psig	min.	31	57	95	233	389	870	1514	3433	6014
	max.	1170	2760	5988	14711	24582	54987	95710	217001	380148



Vortex Flow Meter Model DVH

Order details (Example: DVH- V 15 1 S L L 2 S 0)

Model	Version	Housing	Connection	Material Measuring Tube/ Flow sensor	Sensor Configuration/ Transmitter mounting
DVH-	V = measuring of volume for liquids, gas and steam	15 = DN 15, 1/2" ANSI	1 = ANSI 150 lbs 2 = ANSI 300 lbs 3 = ANSI 600 lbs 5 = DIN PN 40 6 = DIN PN 64 7 = DIN PN 100 X = special	S = st. steel 1.4404/316 L X = special	L = compact, incl. LCD Display 2 = compact, without LCD Display R = separated, incl. LCD Display 3 = separated, without LCD Display X = special
	T = flow velocity incl. temperature sensor	20 = DN 20, 3/4" ANSI 25 = DN 25, 1" ANSI			
	P = flow velocity incl. temperature- and pressure sensor	40 = DN 40, 1 1/2" ANSI 50 = DN 50, 2" ANSI			
	E = option energy consumption	80 = DN 80, 3" ANSI 1H = DN 100, 4" ANSI			
	M = option energy consumption incl. pressure sensor	H5 = DN 150, 6" ANSI 2H = DN 200, 8" ANSI			
	X = special	XX = special			

Power supply	Output options	Process temperature	Pressure sensor
L ¹⁾ = 12 - 36 V _{DC} , loop powered D ²⁾ = 12 - 36 V _{DC} , 4-wire A ²⁾ = 85 - 240 V _{AC} , 50/60 Hz, 12 W	2 = loop powered, 1 x 4-20 mA, Hart®, 1 x pulse H = 1 x 4-20 mA, Hart®, 1 x alarm, 1 x pulse M = 1 x 4-20 mA, 1 x alarm, 1 x pulse 3 = 3 x 4-20 mA, Hart®, 3 x alarm, 1 x pulse 4 = 3 x 4-20 mA, 3 x alarm, 1 x pulse X = special	S = standard -200... +260 °C H = high temperature -200... +400 °C X = special	0 = without 1 = incl. sensor, max. 2 bar abs (30 psia) 2 = incl. sensor, max. 7 bar abs (100 psia) 3 = incl. sensor, max. 20 bar abs (300 psia) 4 = incl. sensor, max. 34 bar abs (500 psia) 5 = incl. sensor, max. 100 bar abs (1500 psia) X = special

¹⁾ only for output option "2"

²⁾ only for output option "H", "M", "3" or "4"



Dimensions Inline Flanged Models

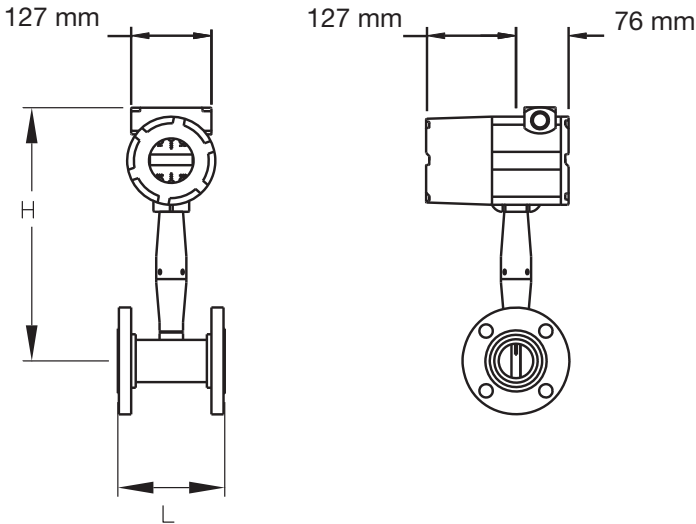

Nominal Size		L		H		Weight		
DN	Inch	mm	Inch	mm	Inch	PN 16/ANSI 150 (kg)	PN 40/ANSI 300 (kg)	PN 64/ANSI 600 (kg)
DN 15	½"	200	approx. 7.87	376	approx. 14.8	5.5	5.7	5.9
DN 20	¾"	200	approx. 7.87	381	approx. 15	5.9	6.4	6.6
DN 25	1"	200	approx. 7.87	381	approx. 15	6.1	7.4	7.4
DN 40	1 ½"	200	approx. 7.87	381	approx. 15	6.6	10.3	11.2
DN 50	2"	200	approx. 7.87	389	approx. 15.3	8.8	12.2	15.1
DN 80	3"	200	approx. 7.87	401	approx. 15.8	12.5	17.9	25.5
DN 100	4"	250	approx. 9.84	411	approx. 16.2	19.7	27.4	43.6
DN 150	6"	300	approx. 11.8	439	approx. 17.3	22	43.6	80.8
DN 200	8"	300	approx. 11.8	462	approx. 18.2	32.2	67.4	136

For remote electronics add 5 kg (11Lb)

Dimensions Wafer Models

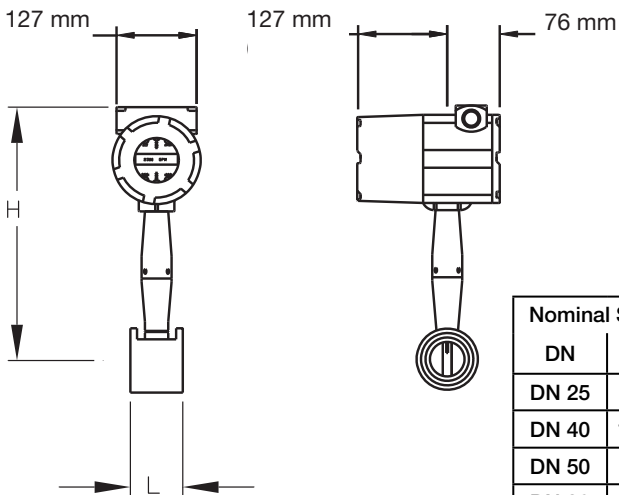

Nominal Size		L		H		Weight
DN	Inch	mm	Inch	mm	Inch	PN 40/ANSI 300 (kg)
DN 25	1"	71	approx. 2.8	376	approx. 14.8	4.6
DN 40	1 ½"	71	approx. 2.8	384	approx. 15.1	5.4
DN 50	2"	76	approx. 3	389	approx. 15.3	6.4
DN 80	3"	102	approx. 4	401	approx. 15.8	10.3
DN 100	4"	119	approx. 4.7	411	approx. 16.2	15

For remote electronics add 5 kg (11Lb)

Dimensions Remote Electronic Option R

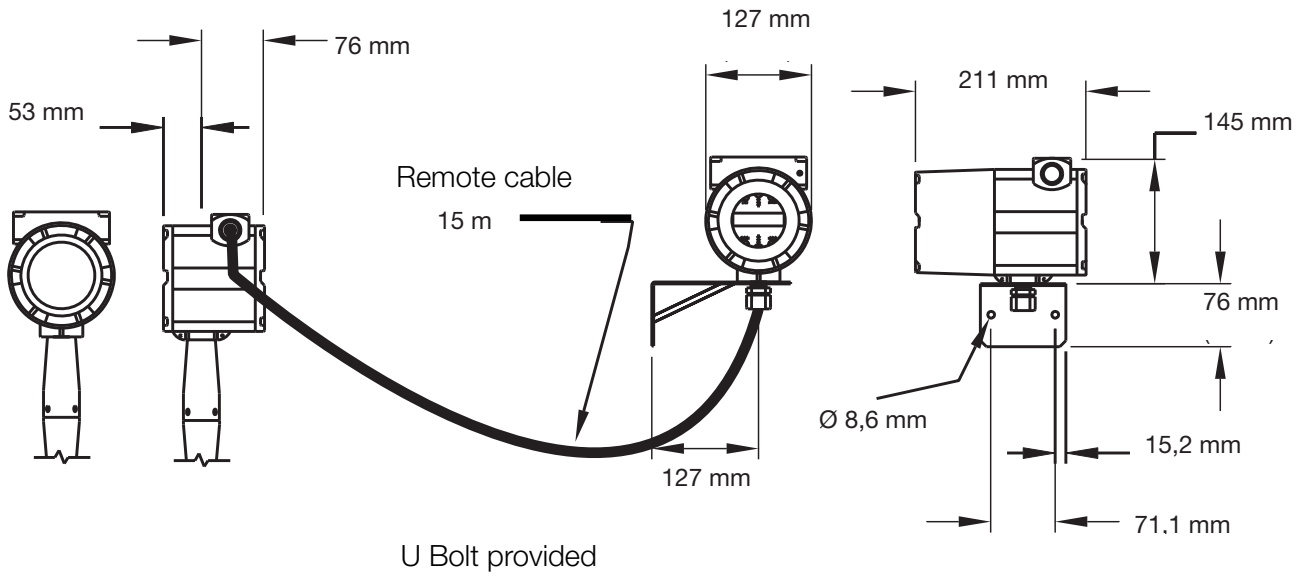

Remote electronics option
available on all models.