



Magnetic-Inductive Flow Meter/Totalizer

for Liquids



measuring
•
monitoring
•
analysing



- Measuring range: 0.01...10 m/s
- No pressure loss with pipe restrictions
- Measurement result not affected by density, viscosity or temperature
- Analogue/frequency and status output
- High accuracy: 0.5% of measured value
- Can be fully emptied, with nothing remaining
- Turndown ratio 1000 : 1



KOBOLD companies worldwide:

ARGENTINA, AUSTRIA, BELGIUM, CANADA, CHILE, CHINA, CZECHIA,
FRANCE, GERMANY, GREAT BRITAIN, INDIA, INDONESIA, ITALY,
MALAYSIA, MEXICO, NETHERLANDS, POLAND, SINGAPORE, SLOVAKIA,
SPAIN, SWITZERLAND, THAILAND, USA, VENEZUELA, VIETNAM

KOBOLD Messring GmbH
Nordring 22-24
D-65719 Hofheim/Ts.
☎ +49(0)6192 299-0
Fax +49(0)6192 23398
E-Mail: info.de@kobold.com
Internet: www.kobold.com

Model:
PMG-...



Description

The new KOBOLD flow meter model PMG works according to the magnetic-inductive principle. In line with Faraday's law, a voltage is induced in a conductor which moves in a magnetic field. The conducting measured medium corresponds with moving conductor. The voltage induced is proportional to the flow velocity and thus a measure of the volume rate of the flow. Minimum electrical conductivity of 5 µS/cm of the medium is a prerequisite. The induced voltage is fed to an instrument amplifier by two measuring electrodes which are in contact with the measured medium. The defined tube diameter is used to calculate the volumetric flow.

Measurement is independent of the medium and its physical properties, such as density, viscosity and temperature.

Fields of application

All volume flows of liquid media with electrical conductivity > 5 µS/cm (for demineralized water > 20 µS/cm) can be measured.

- acids, alkalis
- pastes, slurries
- drinking water, waste water
- sewage sludge
- beer, wine, milk, mineral water
- spirits, molasses, fruit juice
- soft cheese etc.

Technical details (Electronics)

Measuring range:	0.01 - 10 m/s
Turndown ratio:	> 1000 : 1
Minimum conductivity:	≥ 5 µS/cm (liquids in general) ≥ 20 µS/cm (demineralized water)
Accuracy	
pulse output:	± 0.5 % f. s. ± 1 mm/s
current output:	additional typically ± 5 µA

Measurement error [%] of measured value

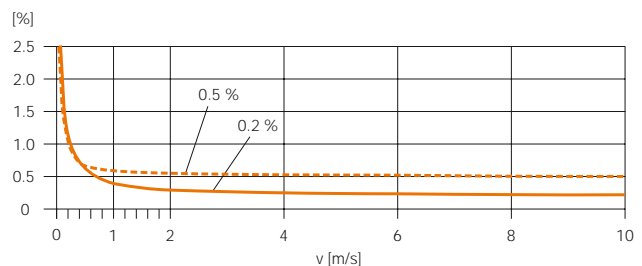

Repeatability:	± 0.1 % f. s. ± 0.5 mm/s
Calibration:	3 measuring points; 0.5 % 3 measuring points; 0.2 %
Media temperature	
nominal size 2 - 15:	-20 to +130 °C (EPDM gasket) -20 to +150 °C (FPM / Kalrez seal)
nominal size 25 - 300:	-20 to +70 °C
Storage temperature:	-10 to +50 °C
Ambient temperature:	-20 to +60 °C
Max. pressure:	PN 40 / 25 / 16 / 10 (depending on nominal size) class 150 / 300 (depending on nominal size)
Inlet pipe straight:	≥ 5 x DN
Outlet pipe straight:	≥ 2 x DN
Materials	
Case material:	aluminium-casting powder-coated, stainless steel 1.4301 (DN 2-15 transducer)
Flange material:	
DIN:	stainless steel 1.4404; PVDF (DN 2 - 15); Steel ST37-2; stainless steel 1.4571 (> DN 25)
ANSI:	316L; PVDF (DN 2 - 15) A105, 316L (> DN 25)
Lining:	PFA (DN 2-15) polyurethane (> DN 25)
Electrode material:	stainless steel 1.4435 or hastelloy C-22
Gasket material:	EPDM, FPM or Kalrez (DN 2 - 15)
Process flange:	DIN or ANSI flange
Cable entry fitting:	M20x1.5; ½ NPT; G ½



Switching/status output: open collector, max. 30 V_{DC} / 250 mA, configurable for: error messages, medium monitoring, direction of flow, limit values

Current output: active/passive selectable; upper range value adjustable
 active: 0/4 - 20 mA, R_L < 700 Ω
 passive: 4 - 20 mA; max 30 V_{DC}; R_i <= 150 Ω

Pulse/frequency output: passive, open collector, 30 V_{DC}, 250 mA, electrically isolated, programmable as pulse or frequency output

Frequency output: end frequency 2 - 1000 Hz (f_{max} = 1250 Hz), mark to space ratio 1 : 1, pulse width max. 10 s

Pulse output: pulse value and pulse polarity selectable, max. pulse width adjustable, (0.5 - 2000 ms)

Status input: U = 3 - 30 V_{DC}, R_i = 5 kΩ configurable for: totalizer reset, measured-value suppression, reset error messages.

Creep suppression: switching points for creep selectable

Galvanic isolation: all circuits for inputs, outputs and auxiliary power are galvanically isolated

Display: LCD, illuminated, two lines - with 16 digits each, measured value/status indication, totalizer

Power supply: 85 - 260 V_{AC}, 45 - 65 Hz
 20 - 55 V_{AC}, 45 - 65 Hz / 16 - 62 V_{DC}

Power consumption: < 15 VA (AC version)
 < 15 W (DC version)

Switching current: max. 13.5 A (< 50 ms) at 24 V_{DC}
 max. 3 A (< 5 ms) at 260 V_{AC}

Protection: IP 67

EMC: EN 61326
 Namur recommendation NE 21

Vibration resistance: to 2 g (in accordance with IEC 68-2-6)

Weights: DN 2-15: 5.2 kg (without process connection)
 separate version: plus 1 kg
 from DN 25: see table
 separate version: plus 1.4 kg

Nominal size [mm]	DIN Nominal pressure	Weight [kg]	Nominal size [inch]	ANSI Nominal pressure	Weight [kg]
25	PN 40	7.3	1"	Class 150	7.3
32		8.0	1 1/4"		-
40		9.4	1 1/2"		9.4
50		10.6	2"		10.6
65	PN 16	12.0	2 1/2"		-
80		14.0	3"		14.0
100		16.0	4"		16.0
125		21.5	5"		-
150	PN 10	25.5	6"		25.5
200		45	8"		45
250		65	10"		75
300		70	12"		110

Selection of nominal sizes

The nominal size of the measuring sensor is normally determined by the pipe diameter. When flow volumes are known the table below can be used to decide whether the ideal flow velocity of approximately 2 - 3 m/s must be observed. If necessary, the nominal size of the measuring sensor can be reduced to increase the flow velocity. Higher installation costs can often be compensated by the low price of a transducer of smaller nominal size.

The flow velocity should be adapted to the physical properties of the measured medium:

- abrasive media: v < 2 m/s (putty, lime milk, ore wash etc.)
- blooming media: v > 2 m/s (for example, waste water sludge)



Nominal size		Recommended flow min/max upper range value (v ~ 0.3 or 10 m/s)	Factory settings		
[mm]	[inch]		upper range value (v ~ 2.5 m/s)	pulse value (~ 2 pulses/s)	creep (v ~ 0.04 m/s)
2	1/12"	0.06...1.8 dm ³ /min	0.5 dm ³ /min	0.005 dm ³	0.01 dm ³ /min
4	5/32"	0.25...7 dm ³ /min	2 dm ³ /min	0.025 dm ³	0.05 dm ³ /min
8	5/16"	1...30 dm ³ /min	8 dm ³ /min	0.10 dm ³	0.1 dm ³ /min
15	1/2"	4...100 dm ³ /min	25 dm ³ /min	0.20 dm ³	0.5 dm ³ /min
25	1"	9...300 dm ³ /min	75 dm ³ /min	0.50 dm ³	1 dm ³ /min
32	1 1/4"	15...500 dm ³ /min	125 dm ³ /min	1.00 dm ³	2 dm ³ /min
40	1 1/2"	25...700 dm ³ /min	200 dm ³ /min	1.50 dm ³	3 dm ³ /min
50	2"	35...1100 dm ³ /min	300 dm ³ /min	2.50 dm ³	5 dm ³ /min
65	2 1/2"	60...2000 dm ³ /min	500 dm ³ /min	5.00 dm ³	8 dm ³ /min
80	3"	90...3000 dm ³ /min	750 dm ³ /min	5.00 dm ³	12 dm ³ /min
100	4"	145...4700 dm ³ /min	1200 dm ³ /min	10.00 dm ³	20 dm ³ /min
125	5"	220...7500 dm ³ /min	1850 dm ³ /min	15.00 dm ³	30 dm ³ /min
150	6"	20...600 m ³ /h	150 m ³ /h	0.025 m ³	2.5 m ³ /h
200	8"	35...1100 m ³ /h	300 m ³ /h	0.05 m ³	5.0 m ³ /h
250	10"	55...1700 m ³ /h	500 m ³ /h	0.05 m ³	7.5 m ³ /h
300	12"	80...2400 m ³ /h	750 m ³ /h	0.10 m ³	10 m ³ /h

Order details (example: **PMG-02 F A 1 1 A 1 W**)

Nom. size	Model	Connection	Gasket/ electrode material	Calibration/ approval	Design
		F =DIN flange PN 40; 1.4404 R =ANSI flange CI 150; 1.4404 U =DIN flange PN 40; PVDF V =ANSI flange CI 150; PVDF 1 =Male thread (DN 2-8: 3/8", DN 15: 1/2") 2 =Female thread (DN 2-8: 3/8", DN 15: 1/2")	A =EPDM-gasket/ 1.4435 B =EPDM-gasket/ Hastelloy C22 C =FPM-gasket/ 1.4435 D =FPM-gasket/ Hastelloy C22 E =Kalrez-gasket/ 1.4435 F =Kalrez-gasket/ Hastelloy C22	1 = 0.5% calibration 2 = 0.2% calibration	1 = Compact version 4 = Separate version with 5 m cable 5 = Separate version with 10 m cable 7 = Separate version please specify cable length in the order
DN 2	PMG-02				
DN 4	PMG-04				
DN 8	PMG-08				
DN 15	PMG-15				
DN 25	PMG-25	A =Steel flange PN 40 (upto DN 150)	A =without gasket/ 1.4435 B =without gasket/ Hastelloy 22		
DN 32	PMG-32	B =Steel flange PN 25 (from DN 200)			
DN 40	PMG-40	C =Steel flange PN 16 (from DN 65)			
DN 50	PMG-50	D =Steel flange PN 10 (from DN 200)			
DN 65	PMG-65	F =St. st. flange PN 40 (upto DN150)			
DN 80	PMG-80	G =St. st. flange PN 25 (from DN 200)			
DN 100	PMG-1H	H =St. st. flange PN 16 (from DN 65)			
DN 125	PMG-1Z	K =St. st. flange PN 10 (from DN 200)			
DN 150	PMG-1F	L =ANSI flange CI 150; A105*			
DN 200	PMG-2H	M =ANSI flange CI 300; A105**			
DN 250	PMG-2F	R =ANSI flange CI 150; 316L*			
DN 300	PMG-3H	S =ANSI flange CI 300; 316L**			

* (DN 25 / 40 / 50 / 80 / 100 / 150 / 200 / 250 / 300 only)

** (DN 25 / 40 / 50 / 80 / 100 / 150 only)

Order details (continued)

Cable gland	Power supply	Output
A =Thread: M20x1.5 incl. screwing B =Thread: 1/2 NPT C =Thread: G 1/2	1 =85 - 260 V, 50/60 Hz 2 =20 - 55 V, 50/60 Hz and 16 - 62 V _{DC}	W =current output A =current and frequency output D =current, frequency, status output; status input

Dimensions

DN 02-15

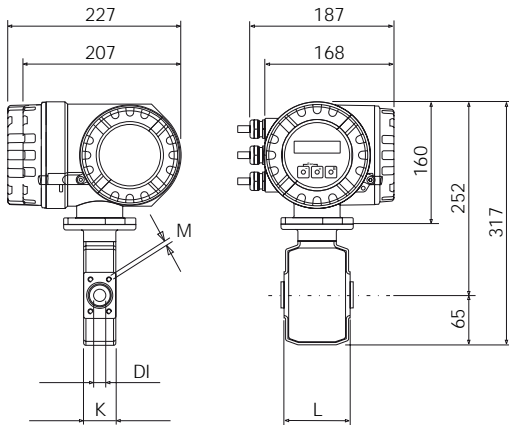

DN [mm]	PN** DIN [bar]	DI [mm]	L [mm]	K [mm]	M [mm]
2	16/40	2.25	86	43	M 6x4
4	16/40	4.5	86	43	M 6x4
8	16/40	9.0	86	43	M 6x4
15	16/40	16.0	86	43	M 6x4

The entire mounting length depends on the process connections.

** The allowed nominal pressure depends on process connection and gasket:
 -40 bar: flange
 -16 bar: all other process connections

Connection F

Flange DIN 2635 / PN 40 / 1.4404 / 316L

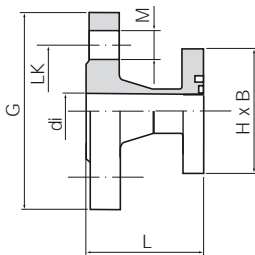

DN		di	G	L	LK	M	HxB
Pipe	Flange	[mm]	[mm]	[mm]	[mm]	[mm]	[mm]
2...8	10	13.6	90	56.2	60	14	60x42
15	15	17.3	95	56.2	65	14	60x42

Mounting length = (2 x L) + 86 mm
 Mounting length acc. to DVGW (200 mm)

Connection R

Flange ANSI 16.5 / CI 150 / 1.4404 / 316L

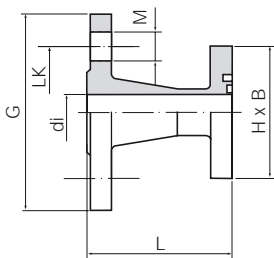

DN		di	G	L	LK	M	HxB
Pipe	Flange	[mm]	[mm]	[mm]	[mm]	[mm]	[mm]
2...8	1/2"	15.7	89	66	60.5	15.7	60x42
15	1/2"	16.0	89	66	60.5	15.7	60x42

Mounting length = (2 x L) + 86 mm

Connection U

Flange DIN 2501 / PN 16 / PVDF

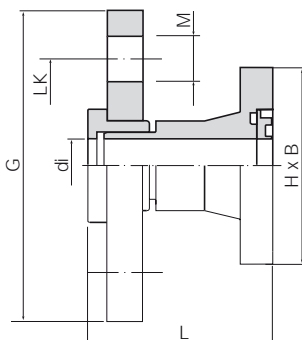

DN		di	G	L	M	LK	HxB
Pipe	Flange	[mm]	[mm]	[mm]	[mm]	[mm]	[mm]
2...8	15	15.7	95	57	14	65	60x42
15	15	15.7	95	57	14	65	60x42

Mounting length = (2 x L) + 86 mm
 Mounting length acc. to DVGW (200 mm)
 The ground-rings are not showed in the diagram.

Connection V
Flange ANSI 16.5 / CI 150 / PVDF

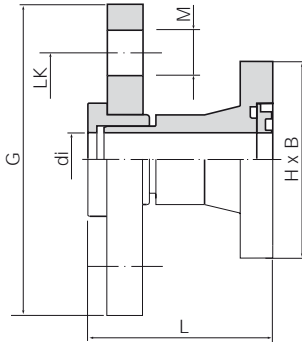

DN	di	G	L	M	LK	HxB
Pipe	Flange	[mm]	[mm]	[mm]	[mm]	[mm]
2...8	1/2"	15.7	95	57	16	60x42
15	1/2"	15.7	95	57	16	60x42

Mounting length = (2xL) + 86 mm
The ground-rings are not showed in the diagram.

Connection 1
Male thread ISO 228 / DIN 2999, 1.4404 / 316L

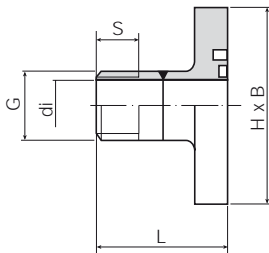

DN	di	G	L	HxB
[mm]	[mm]	[inch]	[mm]	[mm]
2...8	10	3/8"	40	60x42
15	16	1/2"	40	60x42

Mounting length = (2xL) + 86 mm

Connection 2
Female thread ISO 228 / DIN 2999, 1.4404 / 316L

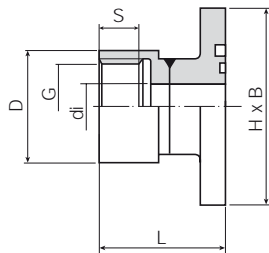

DN	di	G	D	L	HxB
[mm]	[mm]	[inch]	[mm]	[mm]	[mm]
2...8	8.9	3/8"	22	45	60x42
15	16	1/2"	27	45	60x42

Mounting length = (2xL) + 86 mm

Separate versions (DN 2-15)

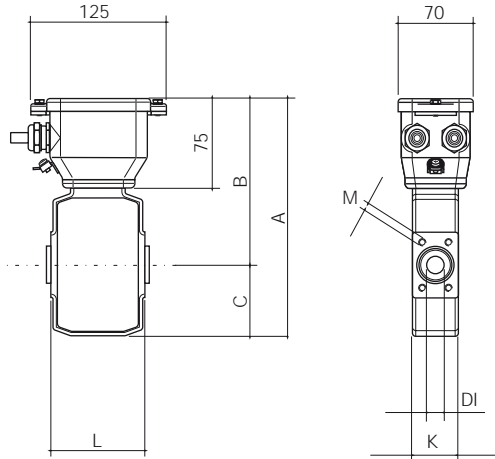

DN	PN*	DI	L	A	B	C	K	M
DIN [mm]	ANSI [inch]	DIN [bar]	[mm]	[mm]	[mm]	[mm]	[mm]	[mm]
2	-	16/40	2.25	86	213	148	65	42
4	-	16/40	4.5	86	213	148	65	42
8	-	16/40	9.0	86	213	148	65	42
15	-	16/40	16.0	86	213	148	65	42

The entire mounting length (L) depends on the process connections..

* The allowed nominal pressure depends on process connection and gasket:

- 40 bar: Flange
- 16 bar: all other process connections

Compact version (from DN 25)

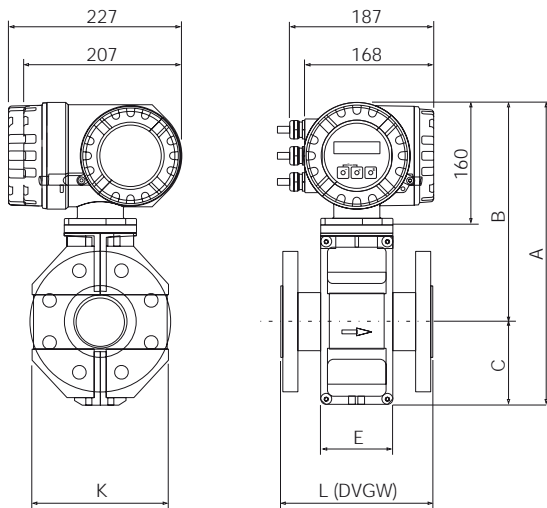

DN	L	A	B	C	K	E
DIN [mm]	ANSI [inch]	[mm]	[mm]	[mm]	[mm]	[mm]
25	1"	200	341	257	84	120
32	-	200	341	257	84	120
40	1 1/2"	200	341	257	84	120
50	2"	200	341	257	84	120
65	-	200	391	282	109	180
80	3"	200	391	282	109	180
100	4"	250	391	282	109	180
125	-	250	472	322	150	260
150	6"	300	472	322	150	260
200	8"	350	527	347	180	324
250	10"	450	577	372	205	400
300	12"	500	627	397	230	460

Mounting length (L) always the same, regardless of selected nominal pressure.

Separate versions (from DN 25)

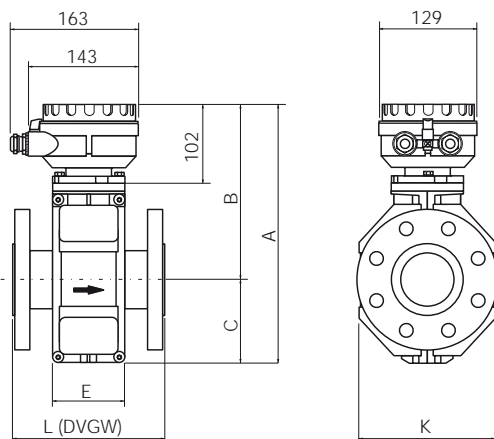

DN	L	A	B	C	K	E
DIN [mm]	ANSI [inch]	[mm]	[mm]	[mm]	[mm]	[mm]
25	1"	200	286	202	84	120
32	-	200	286	202	84	120
40	1 1/2"	200	286	202	84	120
50	2"	200	286	202	84	120
65	-	200	336	227	109	180
80	3"	200	336	227	109	180
100	4"	250	336	227	109	180
125	-	250	417	267	150	260
150	6"	300	417	267	150	260
200	8"	350	472	292	180	324
250	10"	450	522	317	205	400
300	12"	500	572	342	230	460

Mounting length (L) always the same, regardless of selected nominal pressure.