



Digital Manometer with LCD Display

Battery-Operated or 24 V_{DC}



measuring
•
monitoring
•
analysing



- 4-Digit LCD display
- Measuring ranges: -1 to +1600 bar
- Accuracy class: 0.5
- Connection:
G 1/4, G 1/2, 1/4 NPT outer thread,
1/2 NPT outer thread
- Parts in contact with measuring medium:
stainless steel, ceramics, NBR
- Output: 0-2 V_{DC},
4-20 mA, relay
- Peak value memory



KOBOLD companies worldwide:

ALGERIA, ARGENTINA, AUSTRALIA, AUSTRIA, BELGIUM, BULGARIA, CANADA, CHILE, CHINA, COLOMBIA, CZECH REPUBLIC, DOM. REPUBLIC, EGYPT, FRANCE, GERMANY, INDIA, INDONESIA, IRAN, ITALY, MALAYSIA, MEXICO, MOROCCO, NETHERLANDS, PERU, POLAND, SINGAPORE, SLOVAKIA, SPAIN, SWITZERLAND, THAILAND, TUNESIA, UNITED KINGDOM, USA, VENEZUELA, VIETNAM

KOBOLD Messring GmbH
Nordring 22-24
D-65719 Hofheim/Ts.
☎ +49(0)6192 299-0
Fax +49(0)6192 23398
E-Mail: info.de@kobold.com
Internet: www.kobold.com

Model:
MAN-SD
MAN-LD



Description

The intelligent KOBOLD digital manometers are used for the display, monitoring and remote transmission of pressure-dependent operating sequences in machines and installations. The pressure to be measured is sensed by a piezo-resistive sensor and displayed by the electronics. As an option, an analogue output signal for remote transmission of the measured values and a relay output are available. The values are shown on a four-digit LCD display. The front cover along with the display can be rotated.

In the pressure switch design with integrated relay, the switching point and hysteresis can be set on the membrane keypad. The starting and end points of the optional analogue output, relative to the display, are freely scalable. A wide range of process connections is available as an option. The process connection can be rotated in axial direction as desired, after loosening the counter nut.

Fields of application

- Plant construction
- Mechanical engineering
- Environmental technology
- Hydraulics

Technical Data

Display: 4-digit LCD, digit height 12.7 mm
 Measuring ranges: -1...0...+1600 bar (special ranges on request)
 Accuracy class: 0.5
 Temperature coefficient:
 • Zero point: $\leq \pm 0.2\%$ relative to measured value/10 K
 • Range: $\leq \pm 0.1\%$ relative to measured value/10 K
 Zero point correction: $\leq \pm 25\%$
 Overload range: 3 x P_N (to 40 bar)
 2 x P_N (60 to 160 bar)
 1.5 x P_N (250/400/1000/1600 bar)
 1.3 x P_N (600 bar)
 Conversion rate: 5 per second (standard)
 (1 to 10 per second can be set ex works)
 Housing: Ø 74 mm, PA6 GK30, Polyester film

Technical Data (continued)

Wetted parts

Sensor: ceramic (Al₂O₃) (range ≤ 600 bar)
 stainless steel (range > 600 bar)
 Seal: NBR (range ≤ 600 bar)
 Process connection: G 1/4, G 1/2, 1/4 NPT, 1/2 NPT outer thread
 (range ≥ 1000 bar only G 1/2 or 1/2 NPT)
 stainless steel 1.4571
 (other connections on request)
 Temperature of the medium: -30...+85 °C
 Ambient temperature: 0...+60 °C
 Storage temperature: -30...+80 °C
 Allowed relative humidity: $< 90\%$, non-condensing
 Protection class: IP 65
 Electric connection: M12x1 round connector or PVC cable
 Cable length: 0.5 m (standard), max. 3 m
 Weight: approx. 350 g

MAN-SD

Power supply: 9 V_{DC} (block battery, IEC 6 LR 01)
 Service life (based on a conversion rate of 5/s):

Operation	Alkaline battery (Duracell® MN1601, Varta® 4922)	Lithium battery (Ultralife® U9VL-J)
continuous operation	2000 h	5200 h
switched-off	7300 h	17300 h

Automatic switch-off times : 4...64 min (auto-off)
 can only be set ex works;
 0 = inactive (recommended for analogue or switching output)
 Peak value memory: MIN or MAX values, reset via keypad

MAN-LD

Power supply: 24 V_{DC} $\pm 20\%$

Options

Limit value relay: NO contact, bistable, any setting possible, settable hysteresis
 Max. switching power: 30 V_{AC/DC}, 2 A (for relay output)
 Analogue output: MAN-SD: 0 - 2 V_{DC}
 (working resistance: ≥ 100 kΩ)
 MAN-LD: 4-20 mA
 (working resistance: < 500 Ω, galvanically not separated)



Order Details (Example: MAN-SD1S 5 AD 0)

Version	Power supply	Model	Mechanic connection*	Measuring range*	Electric connection
Standard	9 V battery	MAN-SD1S...	5 = G 1/4 AG 6 = G 1/2 AG R = 1/4 NPT AG S = 1/2 NPT AG	AD = -1...0 bar A1 = -1...+1.5 bar A2 = -1...+3 bar A3 = -1...+5 bar A4 = -1...+9 bar A5 = -1...+15 bar B1 = 0...+0.6 bar B2 = 0...+1 bar B3 = 0...+1.6 bar B4 = 0...+2.5 bar B5 = 0...+4 bar B6 = 0...+6 bar B7 = 0...+10 bar B8 = 0...+16 bar B9 = 0...+25 bar B0 = 0...+40 bar C1 = 0...+60 bar C2 = 0...+100 bar C3 = 0...+160 bar C4 = 0...+250 bar C5 = 0...+400 bar C6 = 0...+600 bar D7 = 0...+1000 bar D8 = 0...+1600 bar	0 = none
Relay output	9 V battery	MAN-SD2S...			S = connector M12x1
Output 0-2 V	9 V battery	MAN-SD3S...			K = 0.5 m cable
Standard	24 V _{DC}	MAN-LD1S...			S = connector M12x1
Relay output	24 V _{DC}	MAN-LD2S...			
Output 4-20 mA	24 V _{DC}	MAN-LD3S...			

* Please specify other connections (7/8 UNF for refrigeration technology, M16, etc.) and special measuring ranges in plain text. Measuring ranges starting at 1000 bar are primarily to be connected to the process with G 1/2, 1/2 NPT or M16 female.

Order Details (continued)

Automatic switch-off times	Other options (please specify in plain text)
without = continuous operation (standard except MAN-SD1) B = 4 minutes C = 8 minutes (standard MAN-SD1) D = 16 minutes E = 32 minutes F = 64 minutes	Display in mbar, PSI, hPa etc. Conversion rate 1-10 per sec.

Accessories for round connector M12x1

Electrical connection	Other options (please specify in plain text)
M12-box, Screw terminals, 5-pole	ZUB-KAB-12D500
M12-box, 2 m cable, 4-pole	ZUB-KAB-12K002
M12-box, 5 m cable, 4-pole	ZUB-KAB-12K005
M12-box, Quick-on, 4-pole	ZUB-KAB-12Q000

Dimensions

MAN-SD

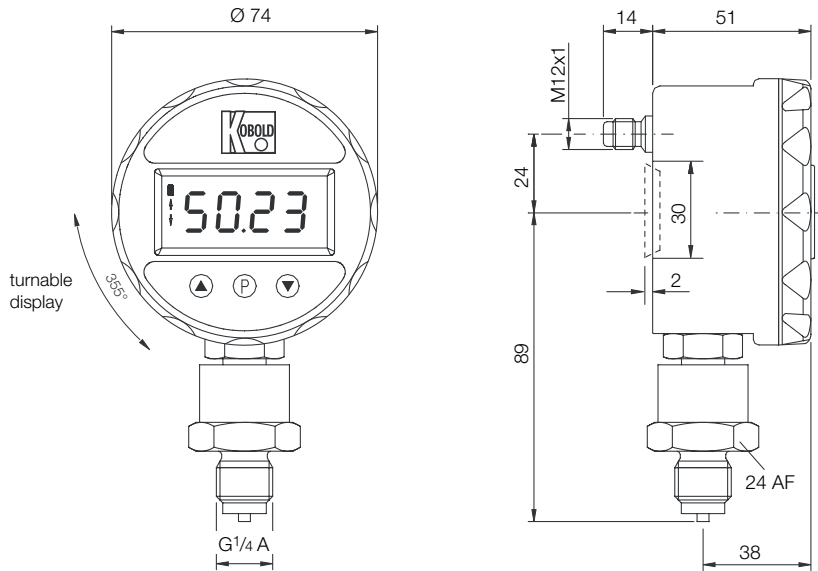

MAN-LD

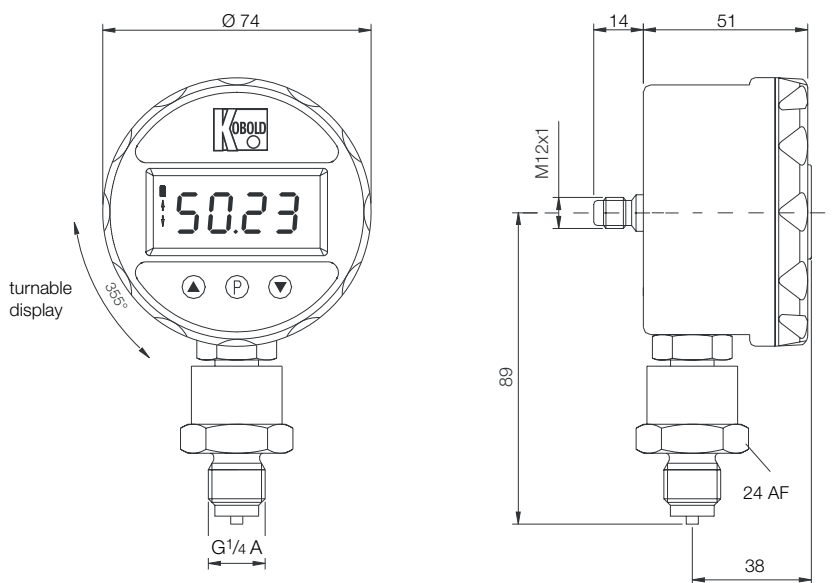

Electric connection: M12 connector assignment

Contact No.	MAN-SD2...	MAN-SD3...	MAN-LD1...	MAN-LD2...	MAN-LD3...
1	-	-	+V _S / 24 V _{DC}	+V _S / 24 V _{DC}	+V _S / 24 V _{DC}
2	NO contact	-	-	NO contact	-
3	-	GND	GND	GND	GND
4	-	Analogue output 0-2 V _{DC}	-	-	Analogue output 4-20 mA
5	NO contact	-	-	NO contact	-