

## Bourdon Tube Pressure Gauges for the Refrigeration



MAN-TE



MAN-TD

- Housing:  
63 mm, 80 mm, 100 mm
- Connection:  
G 1/4, 7/16-20 UNF
- Material:  
Housing: steel, black painted  
stainless steel  
Connection: brass, stainless steel
- Measuring ranges:  
-1...+9 bar to -1...+40 bar
- Scale: pressure and temperature
- Options:  
Liquid filling,  
overrange protection, contacts,  
special housing designs



KOBOLD companies worldwide:

ALGERIA, ARGENTINA, AUSTRALIA, AUSTRIA, BELGIUM, BULGARIA, CANADA, CHILE,  
 CHINA, COLOMBIA, CZECH REPUBLIC, DOM. REPUBLIC, EGYPT, FRANCE, GERMANY,  
 INDIA, INDONESIA, IRAN, ITALY, MALAYSIA, MEXICO, MOROCCO, NETHERLANDS,  
 PERU, POLAND, SINGAPORE, SLOVAKIA, SPAIN, SWITZERLAND, THAILAND, TUNESIA,  
 UNITED KINGDOM, USA, VENEZUELA, VIETNAM

KOBOLD Messring GmbH  
 Nordring 22-24  
 D-65719 Hofheim/Ts.  
 ☎ +49(0)6192 299-0  
 Fax +49(0)6192 23398  
 E-Mail: info.de@kobold.com  
 Internet: www.kobold.com

Model:  
 MAN-T

### Application

Bourdon tube pressure gauges used in refrigeration are used for the simultaneous measurement of vapour pressure and the associated vapour temperature. The gauges can be built with up to 3 temperature scales for use with various cooling agents. They can be provided for the most popular inorganic and organic cooling agents. The stability of the material the pressure gauge is made of must also be taken into consideration. All the pressure gauges comply with general international guidelines and take account of standard as well as application-specific requirements. They are the result of the over 70 years experience we have in building pressure gauges.

### Measuring principle

Mechanical pressure measurement uses the principle of an elastic measuring element, which generates a precisely defined, reproducible deflection when subjected to pressure. The motion works convert this into a rotary motion of the pointer. The pressure at the measuring element can be read on the scale of the dial.

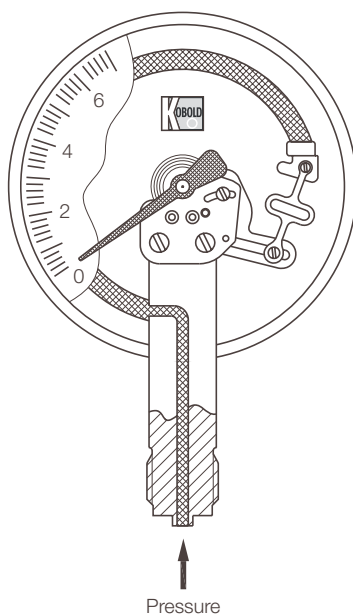

### Temperature scale

There is a direct relationship between pressure and temperature. This is why the pressure gauges can be fitted with a double scale for the measured pressure and the calculated temperature. The temperature scales are based on the vapour tables of saturated cooling agents with a reference pressure of 1013.25 mbar. They are only valid for the pure cooling agent stated on the scale. Since in practice the cooling agents are rarely chemically pure, and because the system pressure usually deviates from the reference pressure, only an approximate temperature can be shown. This is usually quite sufficient in practice.

### Housing

The following housing diameters are available: 63 mm, 80 mm and 100 mm. The housing material is black steel or stainless steel.

### Installation

It can be installed on the delivery side or on the intake side. The gauges are usually installed directly into the customer's threaded connection. For integration into or onto control panels there are options available with an installation profile front or back or a triangular front ring with mounting bracket.

### Connection

Gauges for use with organic cooling agents are supplied with a brass 7/16-20 UNF connection as standard. Stainless steel connectors with G 1/4 or G 1/2 thread connections are available for use with inorganic cooling agents.

### Measuring range

The measuring ranges stated in the technical data have proven to be the most used values. A particular special feature of cooling pressure gauges is that the scale is a combined pressure and temperature scale. The standard scale shows bar and °C. It is also possible to have other scales for temperatures in °F or for pressure in kPa/MPa or PSI. Special scales with your own company logo are also available on request.

### Damping liquid

Pressure gauges with liquid filling are used in locations with high alternating dynamic loads, strong vibrations and pulses. The filling ensures easy readability through steady pointer movement even when subjected to extreme loading and heavy vibration. The lubricating effect of the glycerine also keeps wear to a minimum. Glycerine is always used as a matter of principle.





### Contacts

Liquid paraffin is used as a non-conductive alternative for gauges with contacts or electrical transmitters. Silicon fillings of various viscosities are also optionally available.

### Fields of application:

- Refrigeration and cooling systems

## Technical Data

			for organic refrigeration						for inorganic r.	
Connection/housing			NG 63		NG 80		NG 100		NG 63	
Bottom connection		MAN-...	..TD2V..	..TD7V..	..TE1V..	..TE5V..	..TF2V..	..TF7V..	..TD25..	..TD75..
Back connection		MAN-...	..TD2W.. central	..TD7W.. central	..TE1W.. eccentric	..TE5W.. eccentric	..TF2W.. eccentric	..TF7W.. eccentric	..TD27.. eccentric	..TD77.. eccentric
Triangular front ring and mounting bracket Back connection		MAN-...	..TD2WK.. central	-	..TE1WK.. eccentric	-	..TF2WK.. eccentric	-	..TD27K.. eccentric	-
Front flange Back connection		MAN-...	..TD2WV.. central	-	..TE1WV.. eccentric	-	..TF2WV.. eccentric	-	..TD27V.. eccentric	-
Installation profile back Bottom connection		MAN-...	..TD2VR.. central	-	..TE1VR.. eccentric	-	..TF2VR.. eccentric	-	..TD25R.. eccentric	-
Accuracy class			1.6		1.0		1.0		1.6	
Housing version			stainless steel		stainless steel				stainless steel	
Filling			-	glycerine	-	glycerine	-	glycerine	-	glycerine
Ring			VA rolled		rubber		VA bayonet		VA rolled	
Pointer			Alu							
Movement			brass						stainless steel	
Throttle D=			none							
Window			instrument glass							
Measuring element			CuZn						stainless steel	
Protection			IP 65	IP 68	IP 65	IP 68	IP 65	IP 68	IP 65	IP 68
Overrange protection			1.0							
Weight (without contact)			on request							
Ambient temperature			-20 ... +60 °C							
Connection			brass						stainless steel	
Thread connection			7/16-20 UNF						G 1/4 male	
Max. medium temperature			depending on measuring range							
Contacts			none				3 times		none	
<b>Indicating range, single scale</b>			<b>Code of indicating range</b>							
	-1...+9 bar		..A4..		..A4..		..A4..		-	
	-1...+12.5 bar		..AT..		..AT..		..AT..		..AT..	
	-1...+15 bar		..A5..		..A5..		..A5..		-	
	-1...+24 bar		..A6..		..A6..		..A6..		..A6..	
	-1...+40 bar		..AU..		..AU..		..AU..		-	
<b>Indicating range, double scale/ triple scale</b>			<b>Code of indicating range</b>							
	-1...+9 bar		..A4..		..A4..		..A4..		-	
	-1...+12.5 bar		..AT..		..AT..		..AT..		-	
	-1...+24 bar		..A6..		..A6..		..A6..		-	
<b>Refrigerant medium</b>			<b>Code of refrigerant medium</b>							
Simple scale (pressure and temperature)	R 12		..A		..A		..A		-	
	R 22		..B		..B		..B		-	
	R 23		..C		..C		..C		-	
	R 134a		..D		..D		..D		-	
	R 290		..E		..E		..E		-	
	R 404a		..F		..F		..F		-	
	R 407a		..G		..G		..G		-	
	R 407c		..H		..H		..H		-	
	R 410a		..I		..I		..I		-	
	R 502		..J		..J		..J		-	
	R 507		..K		..K		..K		-	
	R 600		..L		..L		..L		-	
	R 600a		..M		..M		..M		-	
R 717 (NH3)		-		-		-		..N		
special scale		..X		..X		..X		-		
R 134a + R 404a		..O		..O		..O		-		
R 404a + R 407c		..P		..P		..P		-		
R 404a + R 507		..Q		..Q		..Q		-		
R 134a + R 22		..R		..R		..R		-		
special scale		..Y		..Y		..Y		-		
R 22 + R 12 + R 502		..S		..S		..S		-		
R 22 + R 404a + R 407c		..T		..T		..T		-		
R 134a + R 407c + R 507		..U		..U		..U		-		
special scale		..Z		..Z		..Z		-		

Bottom connection

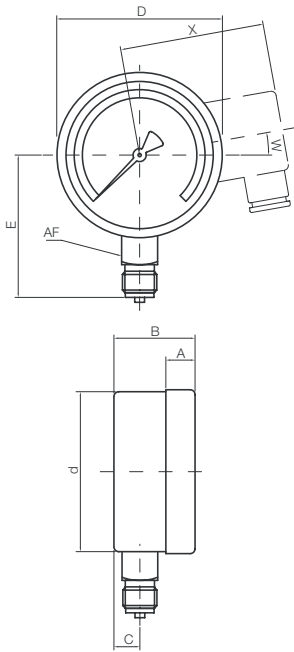

Back connection

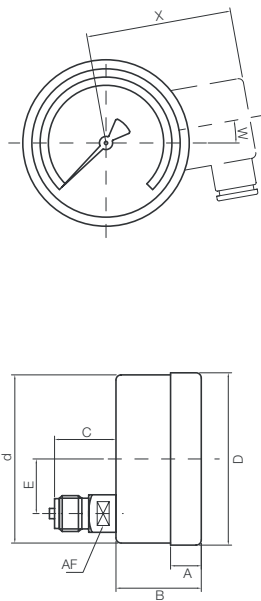

Triangular front ring

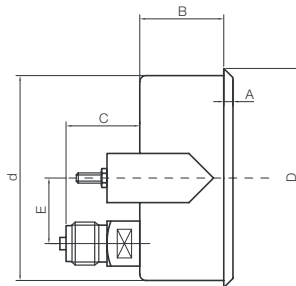

Front flange

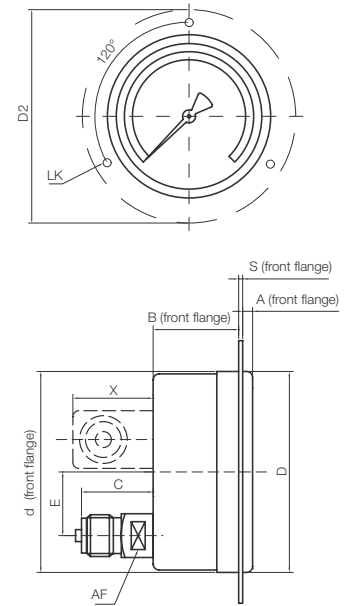

Bottom connection

Code	NG	A	B without contact	B 1 or 2 contacts	B 3 contacts	C	d	D	E	AF
MAN-TD 2V/7V/25/75	63 mm	6	31	-	-	13	62	68	55	14
MAN-TE 1V/5V	80 mm	5	43.5	-	-	16	80	84	76	11
MAN-TF 2V/7V	100 mm	17	48	82	97	15	100	101	86.5	22

Back connection

Code	NG	A	B without contact	B 1 or 2 contacts	B 3 contacts	C	d	D	E	AF
MAN-TD 2W/7W/27/77	63 mm	6	31	-	-	26	63	68	0	14
MAN-TE 1W/5W	80 mm	5	43.5	-	-	35	80	84	23	11
MAN-TF 2W/7W	100 mm	17	49	82	97	36	100	101	32.5	22

Triangular front ring with clamp

Code	NG	A	B without contact	B 1 or 2 contacts	B 3 contacts	C	d	D	E	AF
MAN-TD 2W/27 K	63 mm	6	26	-	-	26	62	68	0	14
MAN-TE 1W K	80 mm	5	43.5	-	-	35	80	84	23	11
MAN-TF 2W K	100 mm	5	41	88	105	36	101	107	32.5	22

Front ring

Code	NG	A	B without contact	B 1 or 2 contacts	B 3 contacts	C	d	D	D2	E	LK	S	AF
MAN-TD 2W/27 V	63 mm	7	24	-	-	26	62	68	85	0	75	1	14
MAN-TE 1W V	80 mm	-	-	-	-	-	-	-	-	-	-	-	-
MAN-TF 2W V	100 mm	6	43	86	92	36	104	101	132	32.5	116	2	22